

RITE-LINK SERIES

Features and Benefits

Right Sized Conveying

The **CAMCO Rite-Link Conveyor** is a thin-profile, preassembled, precision link system offering maintenance free accuracy and durability for industrial conveying applications.

Precision positioning requiring higher precision or speed than roller chain can provide

Material conveying (industrial or medical): for example, narrow cleat or bucket conveyor for constant speed applications. The conveyor can be mounted for either over/under or carousel operation

Features:

Assembly

- Fully designed, assembled and tested for your application
- Can be used in an over/under or carousel configuration

Size

- Slim, compact design with narrow links accommodates oversized tooling
- Easy to integrate
- Servo-friendly for flexible indexing with CAMCO RSD rotary servo drive

Accuracy

- Precision motion from the trusted industry leader
- More accurate and stable than roller chain

Operation

- High operation speeds
- No lubrication needed
- Energy efficient
- Cost Effective

NEW



Maximum Load	Units	75RL...	115RL...	150RL...
Max Load per Link	kg	4	4	4
Max Overhung Load per Link	Nm	1.0	1.0	1.0

* shipping/clearance dimensions

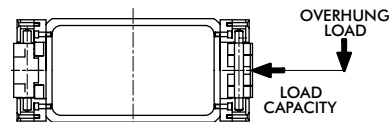
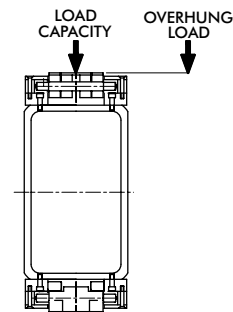

RITE-LINK SERIES

Link Dimensions

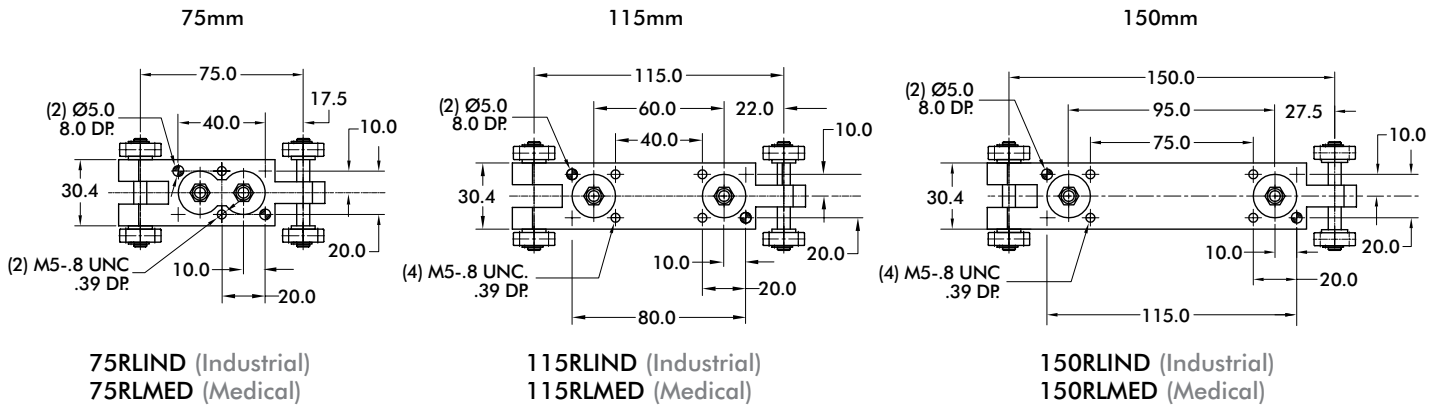

Standard Centers Dimensions

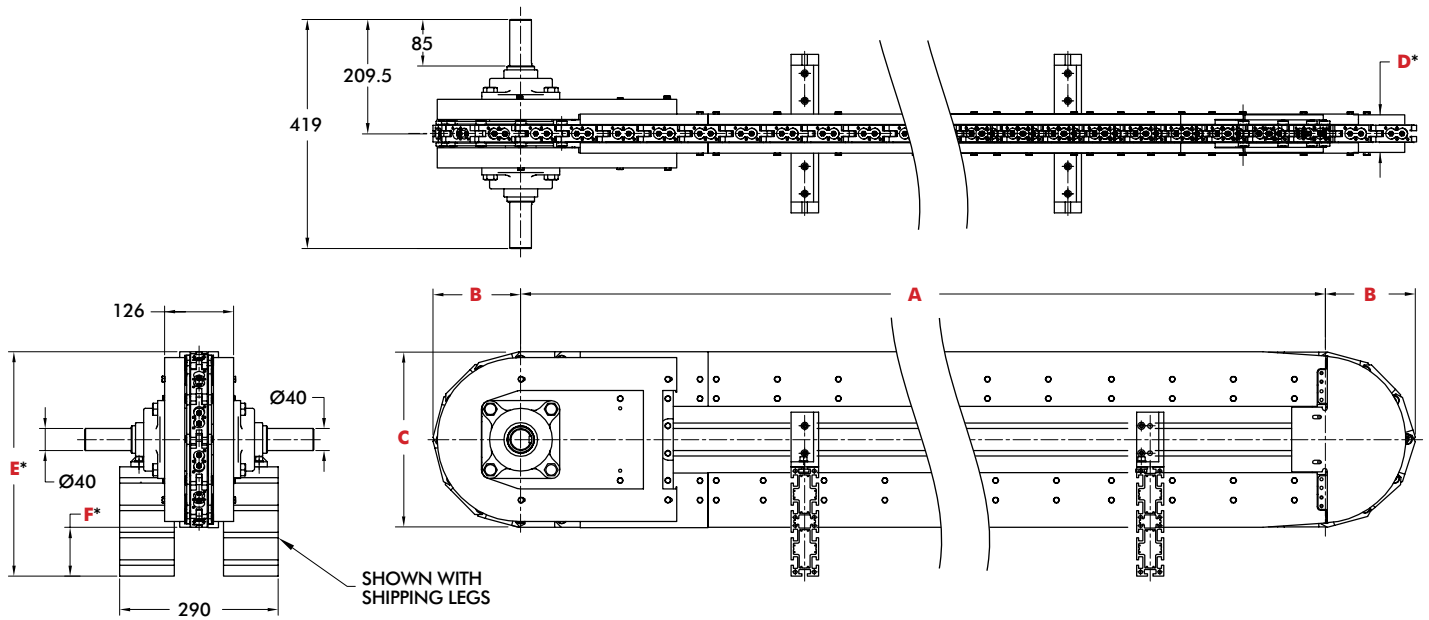

Technical Information

Dimensions	Units	75RL...	115RL...	150RL...
A Standard Center Distances				
Option 1	(meters)	1.20	1.38	1.20
Option 2		2.10	2.30	2.10
Option 3		3.00	3.22	3.00
Option 4		3.90	4.14	3.90
Option 5		4.80	5.06	4.80
B	mm	162.5	166	162.5
C	mm	320	332	332
D*	mm	78.1	78.1	78.1
E*	mm	411	466.2	416
F*	mm	89	133.8	84

* shipping/clearance dimensions