

Product overview

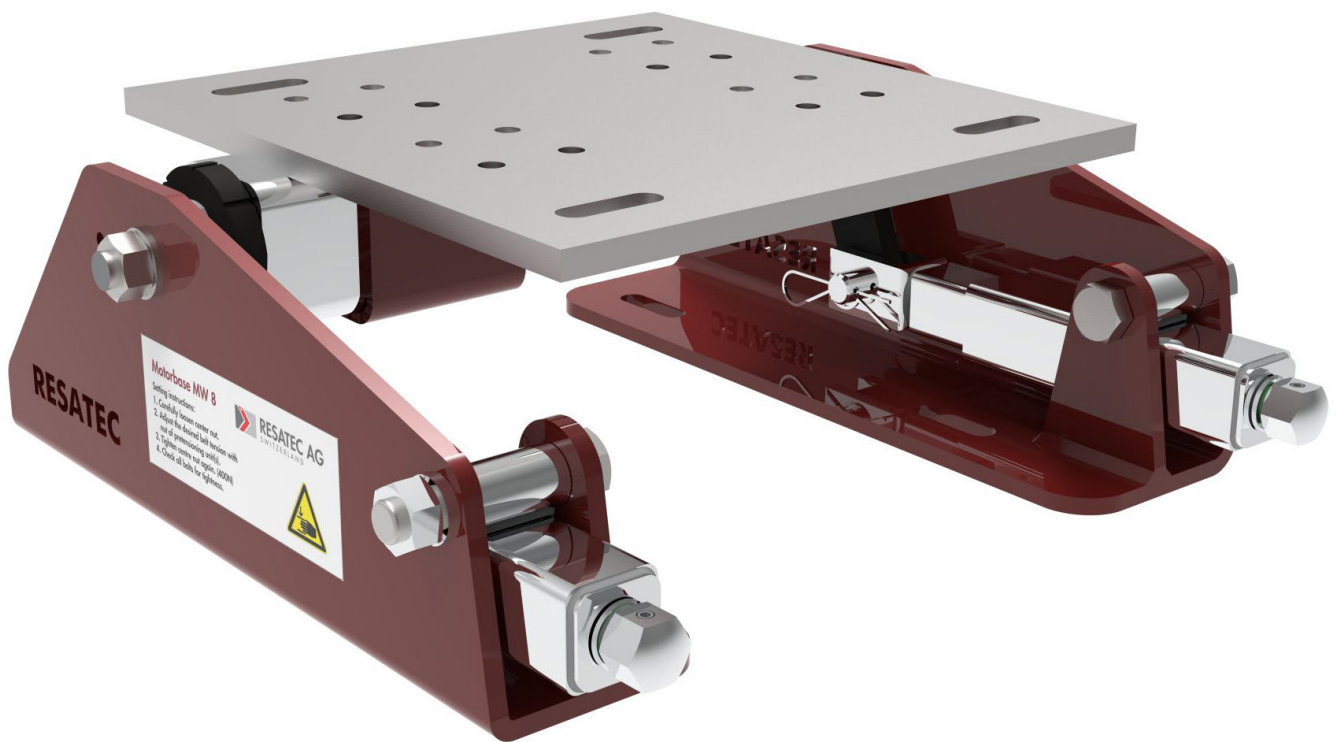

Motor bases

MOTOR BASE MW 8

FOR MOTORS WITH AN OUTPUT OF 7.5 KW TO 45 KW

The RESATEC-MW 8 is the universal motor base for friction belt drives of 7.5 to 45 kW motors. According to the number of belts and belt type, the base can be adjusted in a continuously variable way. It is equipped with two integrated axle stabilizers, robust and maintenance-free pretensioning device and a screw head bracket for simple and safe one-man installation.



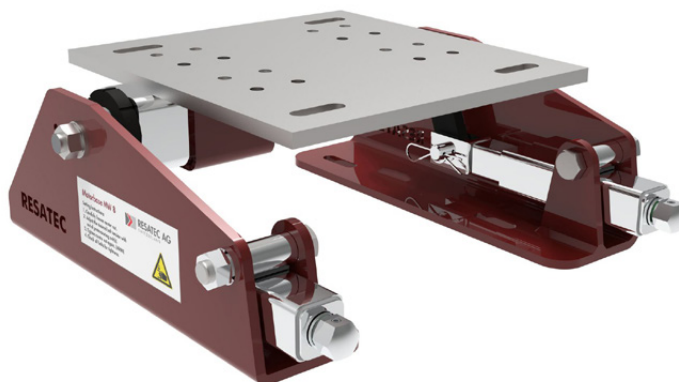

The mounting holes for all motor housing sizes (IEC 160M-225M/NEMA of 254T-365T) are already provided. The use of the RESATEC motor base guarantees the optimal belt tension at any time. This means minimum maintenance and maximum efficiency through a perfect traction.



Advantages at a glance

- The time needed to change the V-belt is reduced by 50 %. No re-alignment of the two drive pulleys when changing!
- Up to four times longer belt life due to correct tension.
- Fewer operating interruptions and protection of the pulleys, bearings and motor shafts.
- Less energy consumption due to optimally tensioned V-belts.
- Accident prevention through safe and easy handling.
- All parts galvanised.
- Maintenance-free.

Mounting area

-  **Drive above**
Motor plate is inclined 30°
-  Max. clamping range, opt. positioning
-  Possible positioning
-  Clarification necessary
-  **Drive below**
Motor plate is horizontal

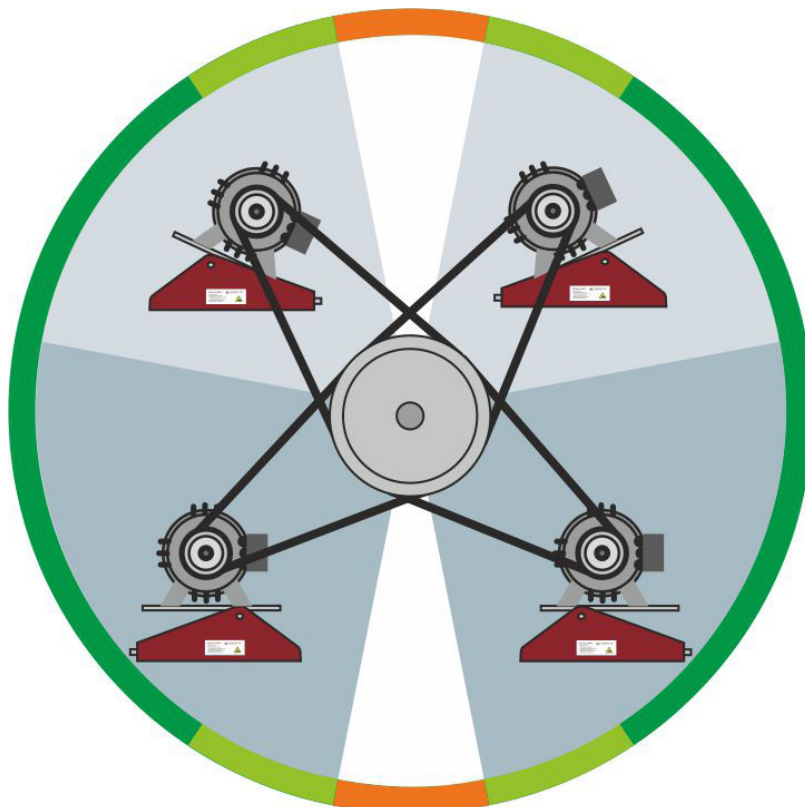

MOTOR BASE MW 8

DIMENSIONS

The motor plate of the MW 8 motor rocker is supplied „offset“ mounted. Depending on requirements, it can also be mounted „centrally“ above the axle. Corresponding mounting holes are already provided. For an increased angle of attack (drive on top), the pre-tensioning levers can be dismantled and remounted in a 45° offset position.

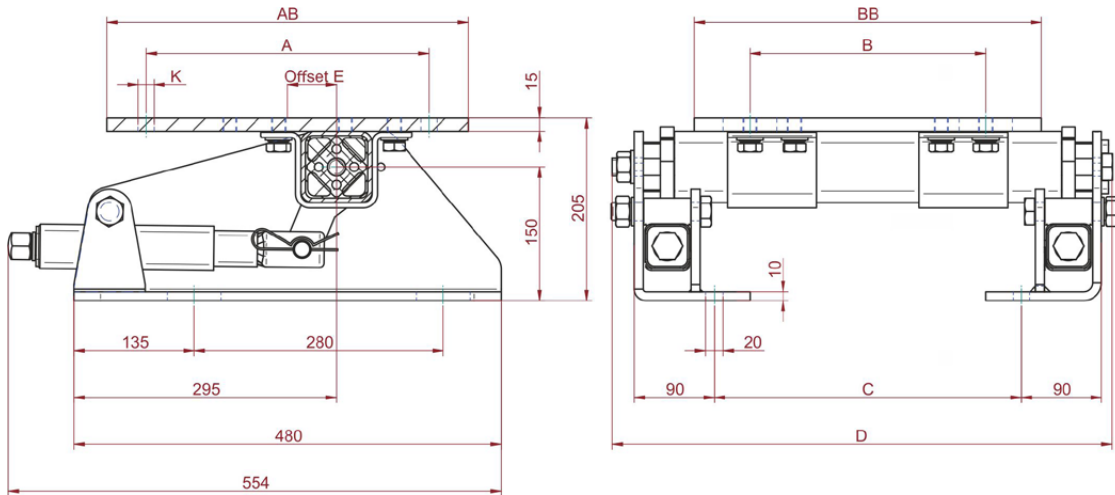

MW 8-270

Motor frame size	Motor power (approx.)		A	B	K	AB	BB	C	D	E	Weight
	IEC 1000 min-1 NEMA 1200 min-1	IEC 1500min-1 NEMA 1800 min-1									
IEC 160M	7.5kW	11 kW	254	210	14	335	350	245	463	38	46
IEC 160L	11 kW	15 kW	254	254	14	335	350	245	463	38	46
NEMA 254T	7.5 hp	15 hp	254	210	14	335	350	245	463	38	46
NEMA 256T	10 hp	20 hp	254	254	14	335	350	245	463	38	46
IEC 180M		18.5 kW	279	241	14	335	350	245	463	38	46
IEC 180L	15 kW	22 kW	279	279	14	335	350	245	463	38	46
NEMA 284T	15 hp	25 hp	279	241	14	335	350	245	463	38	46
NEMA 286T	20 hp	30 hp	279	279	14	335	350	245	463	38	46

MW 8-400

Motor frame size	Motor power (approx.)		A	B	K	AB	BB	C	D	E	Weight
	IEC 1000 min-1 NEMA 1200 min-1	IEC 1500min-1 NEMA 1800 min-1									
IEC 200L	18.5/22 kW	30 kW	318	305	18	406	390	345	554	55	60
NEMA 324T	25 hp	40 hp	318	267	18	406	390	345	554	55	60
NEMA 326T	30 hp	50 hp	318	305	18	406	390	345	554	55	60

MW 8-500

Motor frame size	Motor power (approx.)		A	B	K	AB	BB	C	D	E	Weight
	IEC 1000 min-1 NEMA 1200 min-1	IEC 1500min-1 NEMA 1800 min-1									
IEC 225S		37 kW	356	286	18	466	420	425	643	72	64
IEC 225M	30 hp	45 kW	356	311	18	466	420	425	643	72	64
NEMA 364T	40 hp	60 hp	356	286	18	466	420	425	643	72	64
NEMA 365T	50 hp	75 hp	356	311	18	466	420	425	643	72	64

MOTOR BASE MW 8

ASSEMBLY

Standard installation positions

These recommendations are based on practical experience. A test run shows the ideal installation position.

Overhead

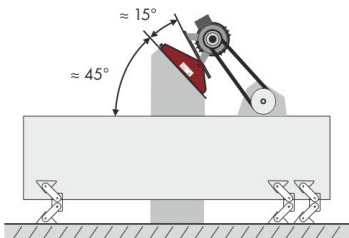

Sideways

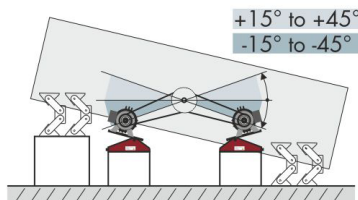

Below *

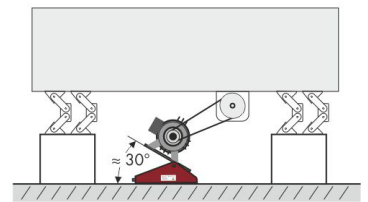

* Extended „offset“ and larger Motor base type recommended

Assembly instructions

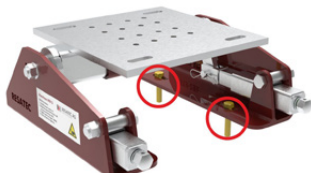

1. Motor base mounting

4 oblong holes 18x60 mm.
Use suitable screws for a safe installation.

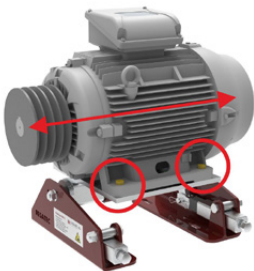

2. Alignment

Tighten with four screws according to the size of the motor.



3. Pulling up and tensioning the belt

Loosen the axle nut. Tension the belts evenly with the pretensioners according to the manufacturer's instructions.



4. Tightening and commissioning

Tighten the axle nut (400 Nm). Start the system.

MOTOR BASE MW 8

BELT TENSIONING

The motor base MW 8 should be pre-tensioned by means of the pre-tensioning device, according to the test force prescribed by the belt manufacturer.

For versions with two pre-tensioning units, ensure synchronous adjustment! The guide values for the most common V-belt profiles are listed in the table. These simplified values are sufficient in most cases.

Exception vibrating screen

With vibrating screens, the belts should only be tensioned to the extent that friction is guaranteed at all times.

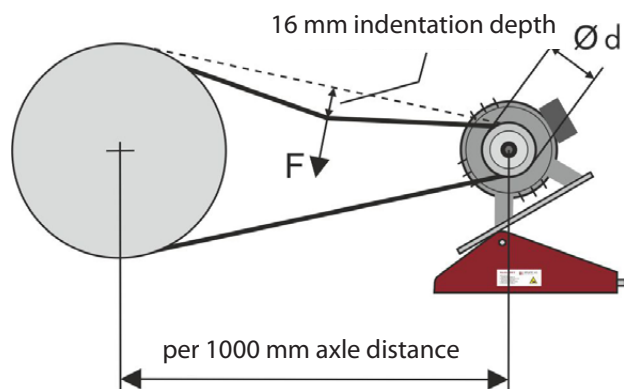

Required indentation depth for intermediate lengths proportionally from 16 mm/m.

V-belt profile	Width [mm]	Height [mm]	Ø d [mm]	Test force F at Start-up [N]	Test force F at operation [N]
XPZ SPZ	10	8	56 - 71	20	16
			75 - 90	22	18
			95 - 125	25	20
			≥ 125	28	22
XPA SPA	13	10	80 - 100	28	22
			106 - 140	38	30
			150 - 200	45	36
			≥ 200	50	40
XPB SPB	16	13	112 - 160	50	40
			170 - 224	62	50
			236 - 355	77	62
			≥ 355	81	65
XPC SPC	22	18	224 - 250	87	70
			265 - 355	115	92
			≥ 375	144	115
Z	10	6	56 - 100	5 - 7,5	
A	13	8	80 - 140	10 - 15	
B	17	10	125 - 200	20 - 30	
C	22	12	200 - 400	40 - 60	
D	32	19	355 - 600	70 - 105	

BELT TENSION



For optimum determination of the necessary test force, we recommend the use of the LüCo Tension Pro belt tension measuring device. Alternatively we also offer the mechanical pressure rod as a tension tester.

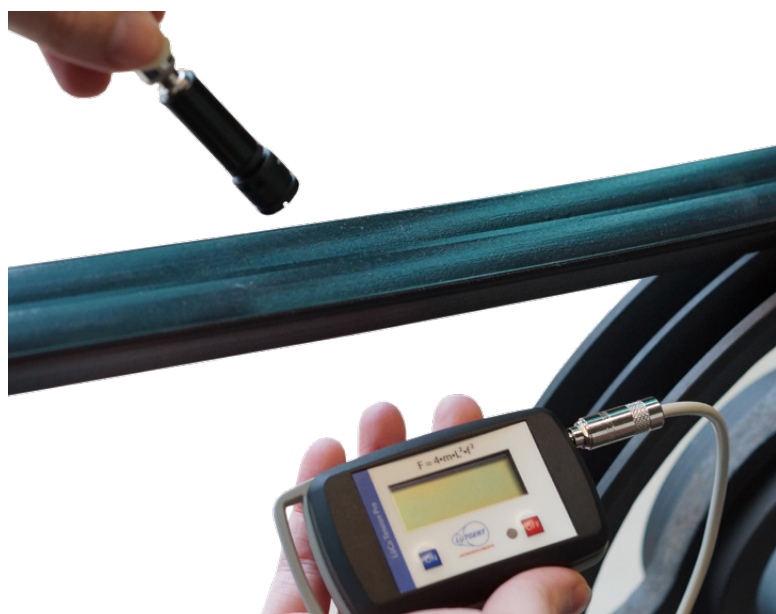

MOTOR BASE MW 10

FOR MOTORS WITH AN OUTPUT OF 37 KW TO 200 KW

The MW 10 motor base is suitable for belt drives with motors from 37 kW to 200 kW power. Depending on the specifications of the drive system, the base can be infinitely adjusted via a single, maintenance-free, centralised pretensioning unit equipped with axial ball bearings. The mounting holes of the motor and base plate are identical and suitable for all motor housing sizes (IEC 250S - 315M / NEMA 404T - 447T). This and the compact design allow easy installation even in existing systems with limited space.

The self-regulating MW10 motor base guarantees optimum belt tension at all times. This means minimal maintenance and maximum efficiency thanks to belt-friendly operation with optimum traction.



Advantages at a glance

- The time needed to change the V-belt is reduced by 50 %. No re-alignment of the two drive pulleys when changing!
- Up to four times longer belt life due to correct tension.
- Fewer operating interruptions and protection of the pulleys, bearings and motor shafts.
- Less energy consumption due to optimally tensioned V-belts.
- Maintenance-free.

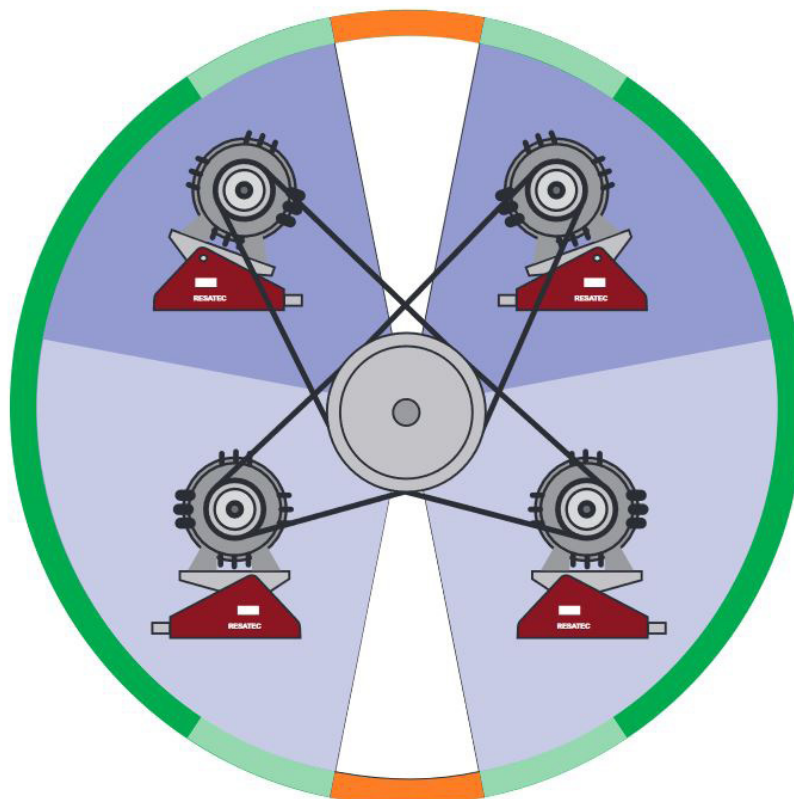

Mounting area

- Drive above**
Motor plate is inclined 20°
- Max. clamping range, opt. positioning
- Possible positioning
- Clarification necessary
- Drive below**
Motor plate is horizontal

MOTOR BASE MW 10

DIMENSIONS

All motor plates of the MW 10 motor base have an „offset“ of 100 mm.

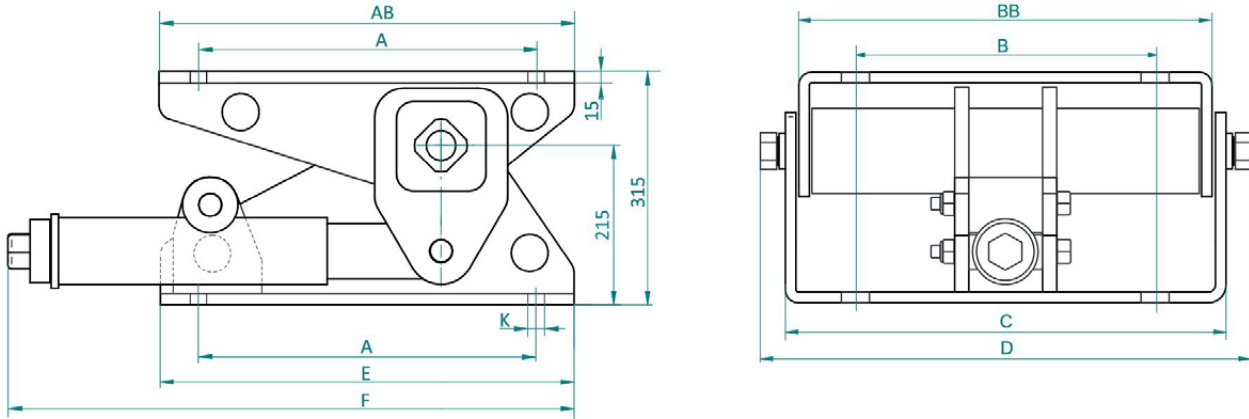

MW 10-450

Motor frame size	Motor power (approx.)		A	B	K	AB	BB	C	D	E	F	Weight
	IEC 1000 min-1 NEMA 1200 min-1	IEC 1500min-1 NEMA 1800 min-1	[mm]									[kg]
IEC 250M	37 kW	55 kW	406	349	22	510	525	560	624	560	765	135
NEMA 404T	60 hp	100 kW	406	311	22	510	525	560	624	560	765	135
NEMA 405T	75 hp	125 hp	406	349	22	510	525	560	624	560	765	135

MW 10-550

Motor frame size	Motor power (approx.)		A	B	K	AB	BB	C	D	E	F	Weight
	IEC 1000 min-1 NEMA 1200 min-1	IEC 1500min-1 NEMA 1800 min-1	[mm]									[kg]
IEC 280S	45 kW	75 kW	457	368	22	560	590	626	690	560	765	148
IEC 280M	55 kW	90 kW	457	419	22	560	590	626	690	560	765	148
NEMA 444T	100 hp	125/150 hp	457	368	22	560	590	626	690	560	765	148
NEMA 445T	125/150 hp	150/200 hp	457	419	22	560	590	626	690	560	765	148

MW 10-700

Motor frame size	Motor power (approx.)		A	B	K	AB	BB	C	D	E	F	Weight
	IEC 1000 min-1 NEMA 1200 min-1	IEC 1500min-1 NEMA 1800 min-1	[mm]									[kg]
IEC 315S	75 kW	110 kW	508	406	26	630	740	776	840	600	800	190
IEC 315M	90/110 kW	132-160 kW	508	406	26	630	740	776	840	600	800	190
NEMA 447T	150-200 hp	200-250 hp	457	508	26/22	630	740	776	840	600	800	190

MOTOR BASE MW 10

ASSEMBLY

Standard installation positions

These recommendations are based on practical experience. A test run shows the ideal installation position.

Overhead

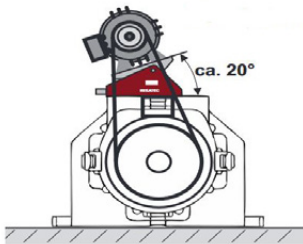

Sideways

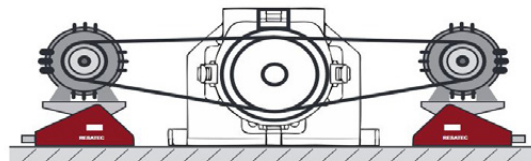

Vibrating screen

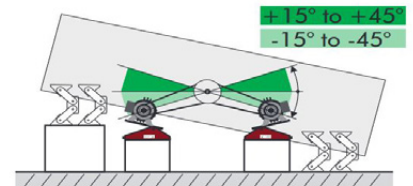

Assembly instructions

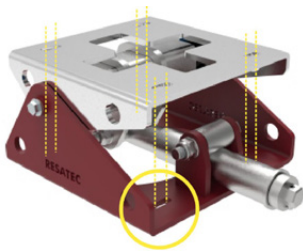

1. Motor base mounting

Four slotted holes with identical hole pattern as the motor plate.



2. Alignment

Tighten with 4 screws according to the motor size.



3. Pulling up and tensioning the belt

Swivel the motor in the direction of the 2nd pulley using the pre-tensioning unit. Pull on the belt and tension with the pre-tensioning unit according to the manufacturer's instructions.



4. Tightening and commissioning

Check that all screws are tight. Start the system.

MOTOR BASE MW 10

BELT TENSIONING

The motor base MW 10 should be pre-tensioned by means of the pre-tensioning device, according to the test force prescribed by the belt manufacturer.

The guide values for the most common V-belt profiles are listed in the table. These simplified values are sufficient in most cases.

Exception vibrating screen

With vibrating screens, the belts should only be tensioned to the extent that friction is guaranteed at all times.

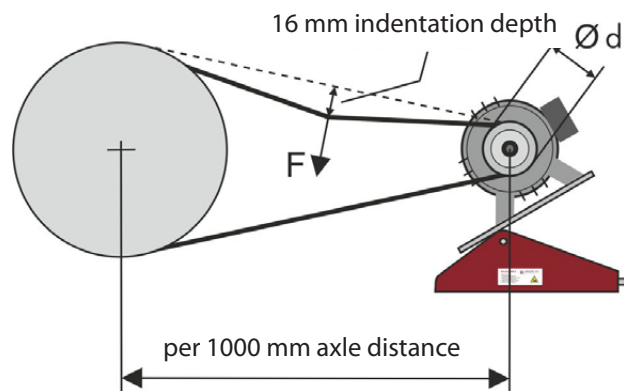

Required indentation depth for intermediate lengths proportionally from 16 mm/m.

V-belt profile	Width [mm]	Height [mm]	Ø d [mm]	Test force F at Start-up [N]	Test force F at operation [N]
XPZ SPZ	10	8	56 - 71	20	16
			75 - 90	22	18
			95 - 125	25	20
			≥ 125	28	22
XPA SPA	13	10	80 - 100	28	22
			106 - 140	38	30
			150 - 200	45	36
			≥ 200	50	40
XPB SPB	16	13	112 - 160	50	40
			170 - 224	62	50
			236 - 355	77	62
			≥ 355	81	65
XPC SPC	22	18	224 - 250	87	70
			265 - 355	115	92
			≥ 375	144	115
Z	10	6	56 - 100	5 - 7,5	
A	13	8	80 - 140	10 - 15	
B	17	10	125 - 200	20 - 30	
C	22	12	200 - 400	40 - 60	
D	32	19	355 - 600	70 - 105	

BELT TENSION

For optimum determination of the necessary test force, we recommend the use of the LüCo Tension Pro belt tension measuring device. Alternatively we also offer the mechanical pressure rod as a tension tester.



FLOHR-PRODUCTS – AT A GLANCE

Gears

- Spiral toothed gears
- Bevel gears
- Worm gears
- Spur gears
- Special gears

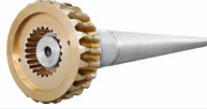

Gearboxes

- Bevel gearboxes
- Angular planetary gearboxes
- Worm gearboxes
- Cam and step gears
- Cam components
- Special gearboxes

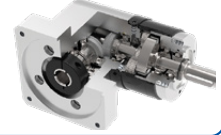

Couplings

- Rigid and flexible couplings
- Friction couplings
- Barrel couplings
- Gear couplings
- Safety couplings

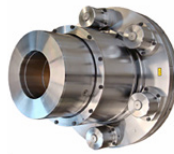

Friction connections

- Shrink discs
- Shaft couplings
- Connecting flanges
- Clamping sets

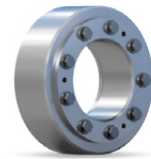

Clamping systems / Automation

- Manual and pneumatic clamping solutions
- Power clamps
- Swivelling units
- End effector solutions
- Linear units
- Grippers



Drive pulleys

- V-belt and flat belt pulleys
- Flywheel pulleys
- Special pulleys
- Motor tensioning systems
- Drive belts
- Customised casting
- Accessories



Sensor systems

- Incremental encoders
- Magnetic encoders
- Absolute encoders
- Overspeed switches
- Electronic position switches
- Universal encoder systems



Contract manufacturing

- Turning, milling, grinding
- Grooving
- Balancing
- Calculation and design
- Assembly
- Service and repair



FLOHR Germany

FLOHR INDUSTRIETECHNIK GmbH
Im Unteren Tal 1
D-79761 Waldshut-Tiengen
Phone: +49 (0) 77 51 / 87 31 0
info@flohr-industrietechnik.de
www.flohr-industrietechnik.de

FLOHR Switzerland

FLOHR INDUSTRIETECHNIK GmbH
Zilistude 164
CH-5465 Mellikon
Phone: +41 (0) 56 / 267 08 10
info@flohr.ch
www.flohr.ch

FLOHR Austria

FLOHR INDUSTRIETECHNIK
Bucherstraße 37b
A-6922 Wolfurt
Phone: +43 (0) 5572 / 372 158
info@flohr.at
www.flohr.at