

Product overview

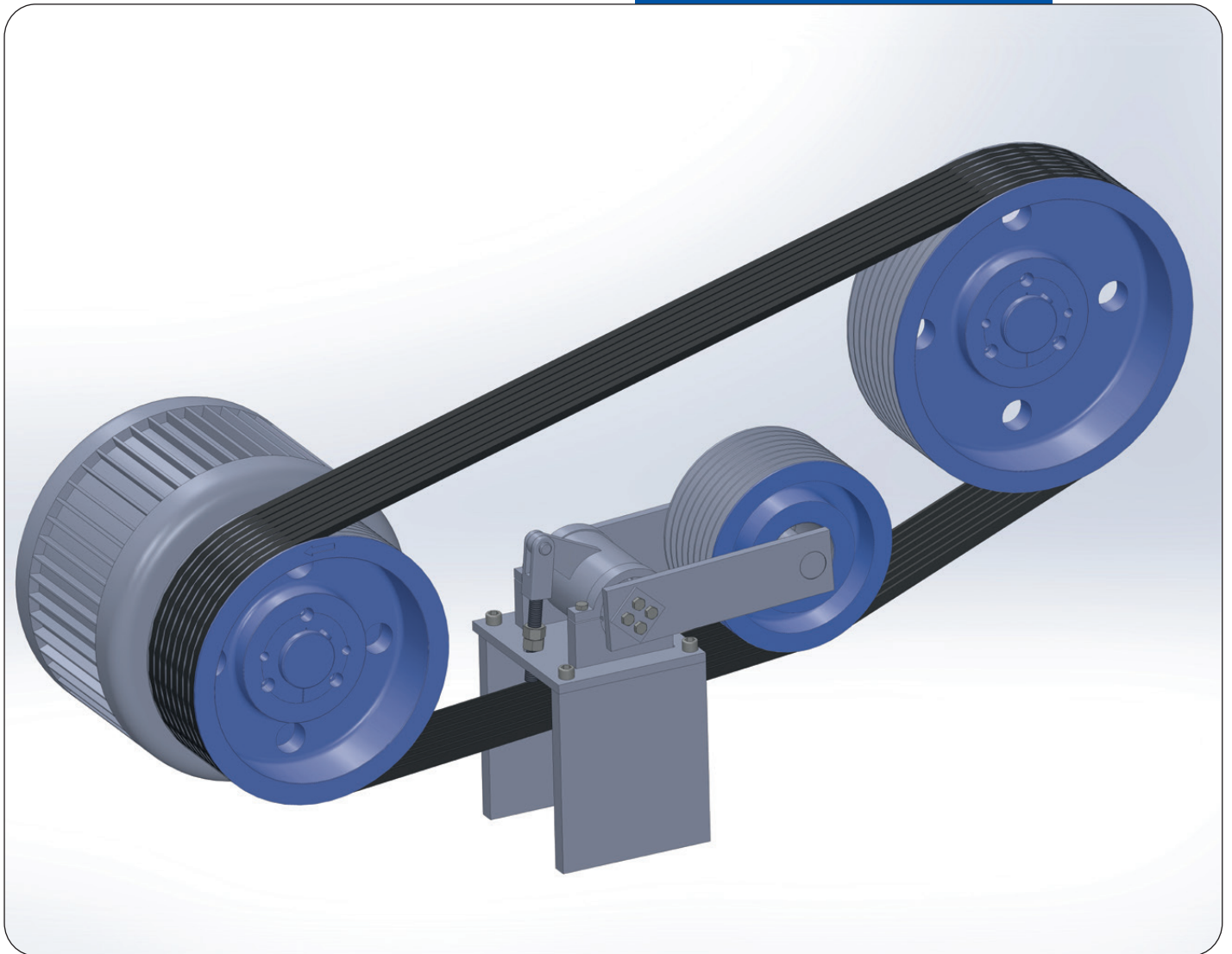

V-belts
Drive belts

V-BELT TYPES | PROFILES

i The choice of the optimum V-belt is decisive efficiency and economy of the entire drive. of the entire drive.

Classic V-belts wrapped DIN 2215

Classic type - reliably used in many drives in mechanical engineering.

Profile name		10/Z	13/A	17/B	20/-	22/C	25/-	32/D	40/E
Upper belt width	b_o	10	13	17	20	22	25	32	40
Belt height	h	6	8	11	12,5	14	16	20	25
Effective width	b_d	8,5	11	14	17	19	21	27	32
Min. pulley diameter	$d_{d \min}$	45	71	112	140	180	224	315	450

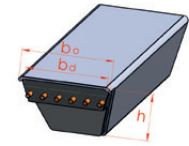

Narrow V-belt wrapped DIN 7753

Further development of the classic V-belt - optimised geometry and improved tension cords for the safe transmission of high power. safe transmission of high power.

Profile name		SPZ/3V/9N	SPA	SPB/5V/15N	19	SPC	8V/25N
Upper belt width	b_o	9,7	12,7	16,3	19	22	25,4
Belt height	h	8	10	13	15,7	18	23,1
Effective width	b_d	8,5	11	14	15	19	25,4
Min. pulley diameter	$d_{d \min}$	63	90	140	224	224	315

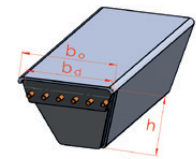

Classic V-belts open flank, tooth form DIN 2215

Well suited for small pulley diameters due to open flanks. Used for many drives in mechanical engineering.

Profile name		5/-	6/Y	8/-	ZX	AX	BX	CX
Upper belt width	b_o	5	6	8	10	13	17	22
Belt height	h	3	4	5	6	8	11	14
Effective width	b_d	4,2	5,3	6,7	8,5	11	14	19
Min. pulley diameter	$d_{d \min}$	16	20	31,5	40	63	90	140

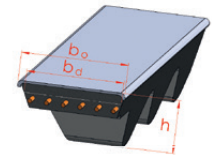

Narrow V-belts with open flanks, tooth form DIN 7753

High power transmission even at high speeds and small pulley diameters.

Profile name		XPZ/3VX	XPA	XPB/5VX	XPC
Upper belt width	b_o	9,7	12,7	16,3	19
Belt height	h	8	9	13	18
Effective width	b_d	8,5	11	14	19
Min. pulley diameter	$d_{d \min}$	50	63	100	160

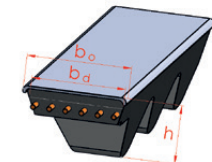

Power belt wrapped

Guaranteed set constancy - suitable for drives with heavy and irregular loads.

Profile name		3V/9J	5V/15J	8V/25J	A/HA	B/HB	C/HC	SPZ	SPA	SPB	SPC
Upper belt width	b_o	9	15	25	13	17	22	9,7	12,7	16,3	22,3
Belt height	h	10	16	25,5	11	14,3	18	11	13	16,5	22
Profile height	H	8	13	23	8	11	14	9	11	13	18
Profile distance	e	10,3	17,5	28,6	15,88	19,05	25,4	12	15	19	25,5
Min. pulley diameter	$d_{d \min}$	71	160	315	85	118	190	71	100	160	265

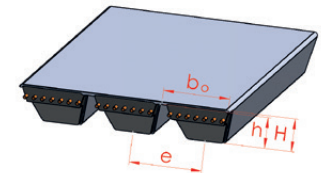

Power belt open flanks

Combines all the advantages of the open-flanked narrow V-belt and the power belt. For the highest demands and powerful power transmission.

Profile name		3V/9J	5V/15J	XPZ	XPA	XPB	XPC
Upper belt width	b_o	9	15	9,7	12,7	16,3	22,3
Belt height	h	10	16	11	13	16,5	22
Profile height	H	8	13	9	11	13	18
Profile distance	e	10,3	17,5	12	15	19	25,5
Min. pulley diameter	$d_{d \min}$	50	100	50	60	100	160

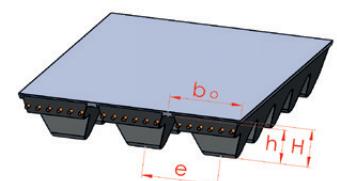

Many high-performance V-belts from various well-known manufacturers in stock. Manufacturer-neutral advice.

FOCUS ON ECONOMY AND PERFORMANCE

The optimum selection of the belt can only be made by considering the power transmission. The requirements for service life are always important, as well as consideration of the operating conditions and, of course, the cost-effectiveness of the overall drive. However, cost-effectiveness is often significantly influenced by the correct selection of belt characteristics. The selection of the most cost-effective belt is usually not the right choice.

A specifically selected high-performance belt is often the superior choice overall compared to a classic V-belt or a standard narrow V-belt. The number of belts can thus be reduced, which directly influences the geometry or the size and, above all, the mass of the pulleys. These relationships are explained below.

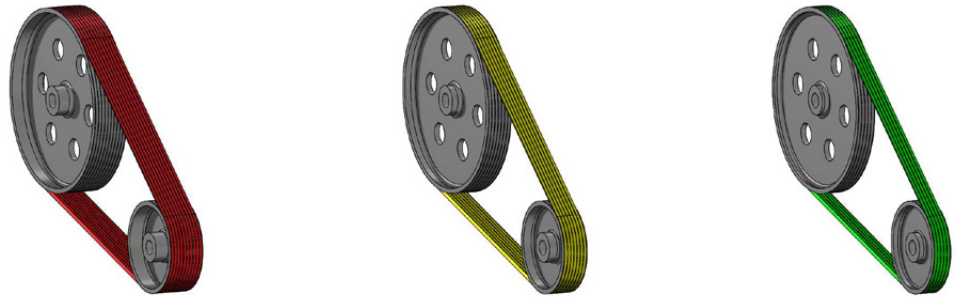

	Classic V-belts DIN 215	Narrow V-belt DIN 7753	High performance Narrow V-belt
Number of belts	10	7	5
kW per belt	8,4	12,1	17,7
Cost per belt	34	44	52
Cost per set	340	308	260
Costs per pulley	710	490	350
Total costs	1050	798	610
	100%	75%	58%

Motor data for the invoice

i

 Engine power 55 kW
 Engine speed 1500 min-1
 Gear ratio 5:1
 Load factor 1.6

Increased performance through high-performance V-belts

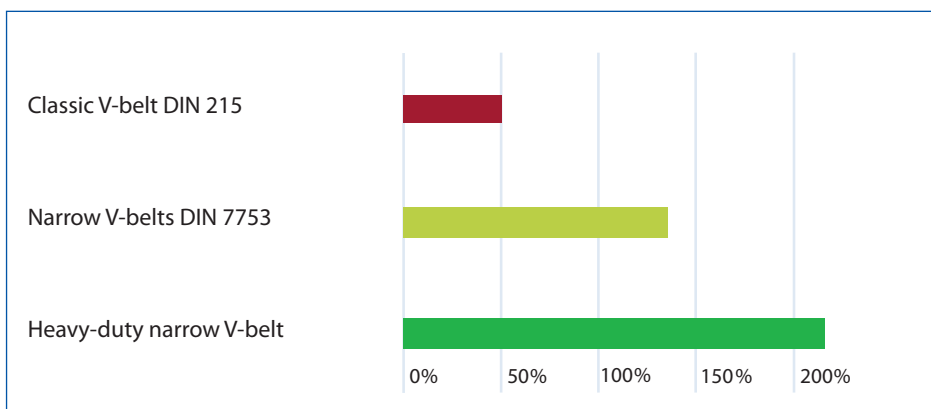

In recent years, high-performance V-belts have been continuously developed and optimised.

This graphical representation must be examined in relation to the specific application.

The influence of temperature, material properties, tensile cords, layers and their alignment are only some of the factors that we consider for you in order to select your very specific belt.

V-BELT CHARACTERISTICS

According to the requirements and the external influences, V-belts must fulfil special requirements. Here is an overview of possible properties:

OIL CONSTANT

Oil resistance means that the V-belt is resistant to the harmful influence of mineral oils and greases, provided that these do not come into contact with the V-belt constantly and in large quantities. Vegetable and animal fats as well as water-soluble cooling lubricants also negatively affect the service life.

TEMPERATURE CONSTANT

All V-belts are generally suitable up to an ambient temperature of -15°C to 70°C. Temperatures outside this range cause the V-belt to age much sooner. It becomes brittle and fragile. In this case, the use of special V-belts should be checked.

MAINTENANCE FREE

To keep the maintenance effort low, the use of maintenance-free belts is recommended. These are characterised by reinforced tensile cords and cover layers that maintain the tensile stress permanently.

SET CONSTANT

All belts that have an individual tolerance of 6 mm to each other are combined into the respective sets. Some manufacturers offer a general limited tolerance of +/-3 mm for certain belt types. These can then be used untested as a set in a drive.

ELECTRICAL CONDUCTIVE

Due to the electrical conductivity, electrostatic charges can be safely discharged. Under certain circumstances, these charges can be so strong that ignition sources are created by sparking. The use of electrically conductive V-belts usually requires a specific test according to ISO 1813.

MINING APPROVAL

The use of V-belts in underground mining or in fire and explosion hazardous areas above ground requires special approval by the Landesoberbergamt Nordrhein-Westfalen and the National Coal Board.



MEASUREMENT AND ADJUSTMENT TECHNOLOGY

LüCo LaserPro© Measuring tool for belt alignment



- Compact and handy design
- Time-saving and accurate measuring method
- Measurement of parallel and angular misalignment
- Robust, anodised aluminium housing
- Powerful line laser
- Focusable laser line
- Measuring pins with magnet
- Applicable on all materials due to adhesive pads

LüCo TensionPro2© Measuring device for belt tension



- Non-contact, acoustic measurement
- Suitable for all belt and tension member types
- Small sensor head on flexible gooseneck
- Ergonomic shape for optimum one-handed use
- Integrated, rechargeable lithium polymer battery
- Measuring range: 10 - 600 Hz
- Measuring accuracy: 10 - 400 Hz: $\pm 1\%$
400 - 600 Hz: $\pm 2\%$

Simple voltage tester | Measuring range 30 lbs ~ 13.6 kg



Dual voltage tester | Measuring range 66 lbs ~ 29.9 kg



Profile gauges for wear control

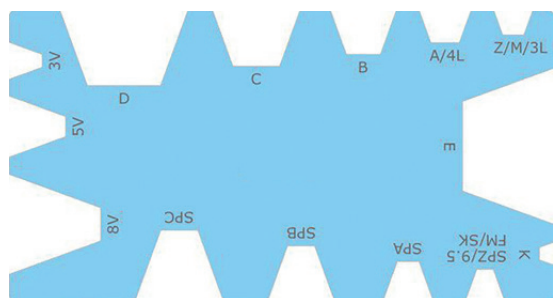

PRODUCT OVERVIEW

EXTRACT

Drive pulleys

V-belt pulleys | V-belt pulleys | Flywheels | Grid pulleys | Timing belt pulleys | Rubberized Pulleys | Split pulleys | Aluminium pulley

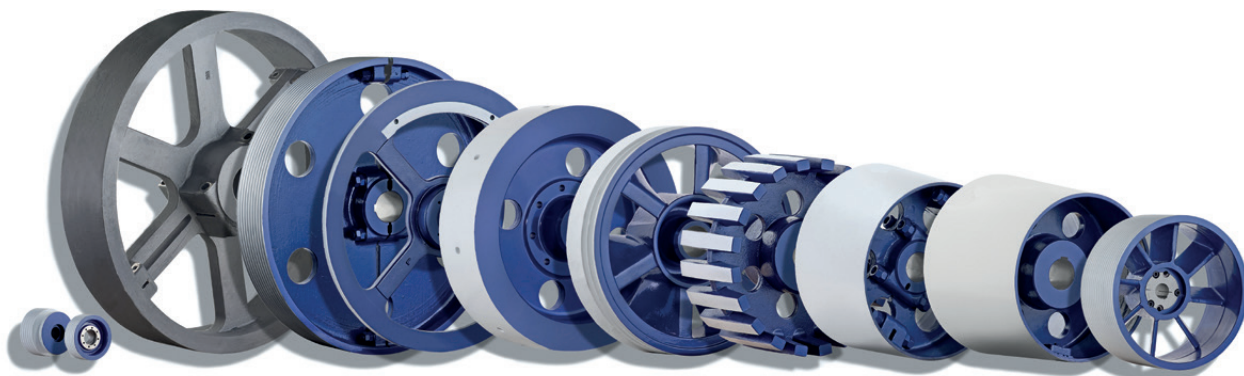

Supplies for drive belts

TaperLock clamping bushes | Motor clamping systems | V-belts / Drive belts | V-belt metrology | Rubber suspension units
Oscillating mountings | Tensioner devices | Foundation blocks | Shafts and rolls



FLOHR Germany

Flohr Industrietechnik GmbH
Im Unteren Tal 1
D-79761 Waldshut
Phone +49 7751 8731-0

info@flohr-industrietechnik.de
www.flohr-industrietechnik.de

FLOHR Switzerland

Flohr Industrietechnik GmbH
Zilistude 164
CH-5465 Mellikon/AG
Phone +41 56 267 08 10

info@flohr.ch
www.flohr.ch

FLOHR Austria

Flohr Industrietechnik
Bucherstraße 37b
A-6922 Wolfurt
Phone +43 5572 372 158

info@flohr.at
www.flohr.at