

ROLLERS TORQUE LIMITERS

up to 12 KNm and 120 mm bore diameters

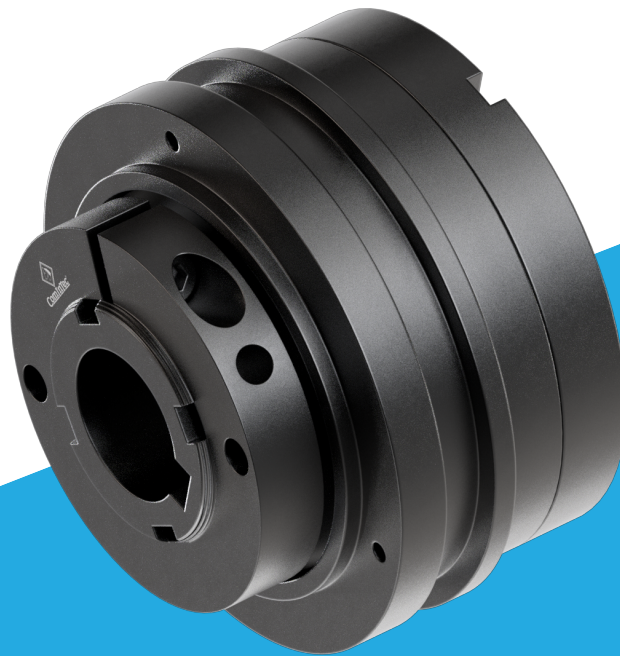

ED. 07/2021 Rev.01



- Download catalogue
- Download instruction sheets
- Download 3D and 2D cad model

DSR

DSR - rollers torque limiter: introduction

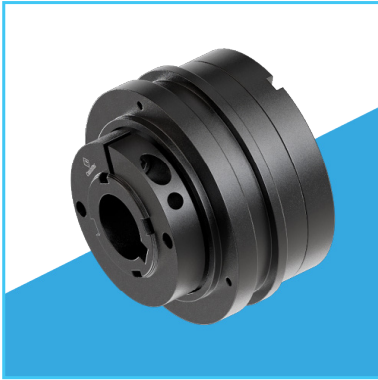

- ⦿ Precise torque setting by adjusting the radially balanced locking nut.
- ⦿ Innovative calibration system by "H dimension" for an immediate calibration of the device.
- ⦿ Equidistant re-engagement in phase or at 360°.
- ⦿ Available with electromechanical switch / proximity for the transmission disconnection.
- ⦿ Immediate intervention for an improved reaction compared to electronic systems.
- ⦿ Maintenance-free for long lasting high reliability.
- ⦿ Suitable for oily and wet environments.

ON REQUEST

- ⦿ Complete with transmission gear, fully turned and mounted (plate wheel, pulley, gear pair).
- ⦿ Possibility to use helical springs for low intervention torques.
- ⦿ Connections with bore and keyway, locking assembly possible.
- ⦿ Version with personalized re-engagement in phase 36°, 45°, 60°, 90°, 120°, ... possible.

Safety coupling with the transmission of motion through rollers that allow complete disengagement when the calibrated torque is reached permitting a quick stop of the transmission due to micro-EM1. Suitable for transmitting high torque with high reliability and compact size.

MAIN APPLICATIONS

- ⦿ Packaging and wrapping machines.
- ⦿ Labelling machines.
- ⦿ Bottling machines.
- ⦿ Conveyors.

ADVANTAGES AND BENEFITS

- ⦿ Protects the gearbox from jamming due to foreign matters.
- ⦿ Protects packages from squashing and deforming.
- ⦿ Protects the product handling elements from accumulations.
- ⦿ Maintains the timing between driver and driven after an overload.

	DSR: Basic model.	from 2,5 to 12.000 Nm 120 mm max bore	Pag. 23
	... / FS: suitable for the mounting of simple transmission.	from 2,5 to 12.000 Nm 120 mm max bore	Pag. 24
	... + GTR: connection with torsionally rigid coupling.	from 2,5 to 2.600 Nm 90 mm max bore	Pag. 25
	... + GAS: connection with flexible coupling with high misalignments.	from 2,5 to 7.000 Nm 130 mm max bore	Pag. 25
	... + GEC: connection with flexible coupling with reduced misalignment.	from 2,5 to 12.000 Nm 180 mm max bore	Pag. 26

EXAMPLE OF ASSEMBLY

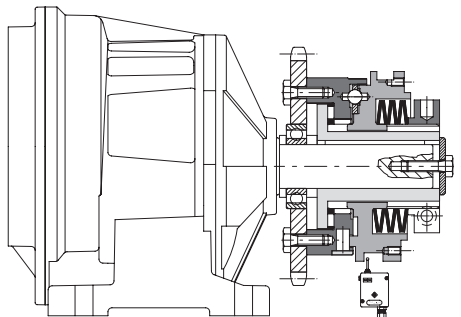

*Model DSR (or DSS) with organ supported by a bearing
Transmission parallel shaft.*

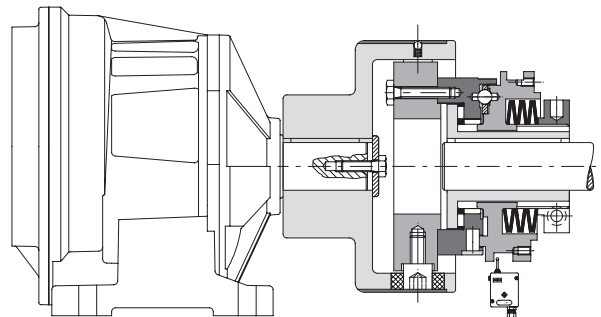

*Model DSR (or DSS) with elastic coupling compact GEC
for transmissions to coaxial shafts.*

DSR - rollers torque limiter: models

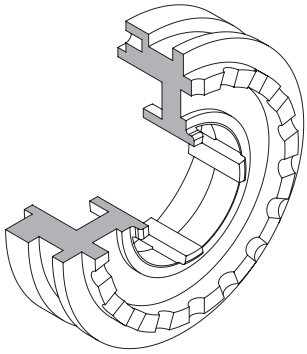

DSR: Roller torque limiter for steady transmission with high torques and vibrations

- Roller transmission.
- Equidistant automatic re-engagement.
- High torque settings at reduced dimensions.
- Same intervention torque in both directions.
- Torque range from 10 to 12,000 Nm; max. bore \varnothing 120 mm.

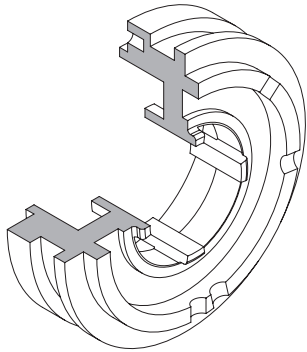

DSR/F: Roller phase torque limiter, synchronised connection between input and output.

- Roller transmission.
- Optimized roller arrangement (patented) with perfect stability and 3 point contact.
- Automatic re-engagement in phase 360° or personalized (36°, 45°, 60°, 90°, 120°, ...)
- High torque settings with compact dimensions.
- Torque range from 10 to 12,000 Nm; max. bore \varnothing 120 mm.

The safety devices ComInTec with reengagements in “phase” are characterized by a unique distribution of the rollers that represents the mathematically optimal solution to have a secure support balanced in all possible positions within 360°. When the limiter disengages, there are always at least three equally spaced rollers that rest on the rolling surface.

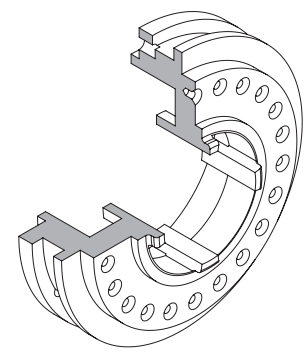

DSS: Ball torque limiter with optimum sensitivity in case of sudden torque variations (ON REQUEST)

- Ball transmission.
- High sensitivity and immediate intervention in case of minimal torque variation.
- Equidistant automatic re-engagement.
- Same intervention torque in both directions.
- Torque range from 2.5 to 2,050 Nm; max. bore \varnothing 68 mm.

NUMBER OF RE-ENGAGEMENTS IN 360 DEGREES

Model	Size							
	0.56	1.90	2.110	3.130	4.160	5.194	6.240	7.280
DSR	18	18	16	16	16	24	24	24
DSR/F	1	1	1	1	1	1	1	1
DSS	24	22	20	20	22	15	-	-

DSR - rollers torque limiter: versions

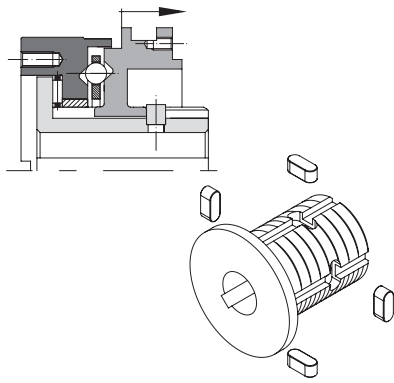

.../TAS: Torque limiter with stop pins

- Complete disconnection prevented.
- Minimum movement of the mobile base for an electrical signal to stop transmission.
- Roller or ball transmission.
- Torque range from 2.5 to 2,800 Nm; max. bore $\varnothing 68$ mm.
- Suitable for applications where the drive must not be disconnected.

The stop pins inserted in the central support as shown in the figure serve to limit the axial stroke of the device, preventing its complete disengagement and thus maintaining a stable transmission connection.

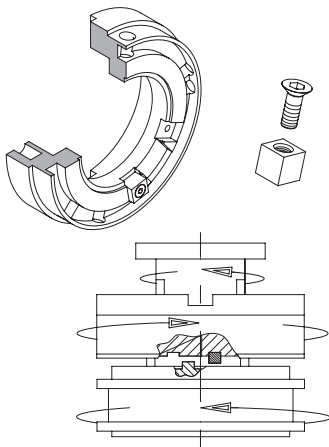

.../AM: Torque limiter with mechanical disconnection to maintain the timing between driver and driven

- Stop pin (patented) resists 4 times the maximum torque.
- 345° rotation allows the cancellation of the residual torque before the device stops.
- Maintains the timing and re-engages in the same position.
- High torque settings at reduced dimensions.
- Torque range from 10 to 2,800 Nm; max. bore $\varnothing 68$ mm.

To allow our engineers to select the correct direction "SX" or "DX" for your application, we require a drawing showing:

- how the unit will be mounted on to the shaft (orientation).
- the direction of rotation
- confirm which drive will continue to rotate after the overload,
- the shaft or plate wheel, pulley, etc.

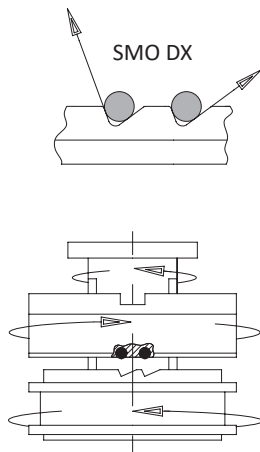

.../SMO: Torque limiter with different disengagement torques from clockwise to anti-clockwise rotation.

- Different intervention torques in the two rotation directions (patented).
- Locking of one direction possible.
- Roller transmission with automatic re-engagement.
- Available with equidistant re-engagement or personalized angular phases.
- Torque range from 10 to 12,000 Nm; max. bore $\varnothing 120$ mm.

To allow our engineers to select the correct direction "SX" or "DX" for your application, we require a drawing showing:

- how the unit will be mounted on to the shaft (orientation).
- the direction of rotation.
- in which direction the high/low torque is required.

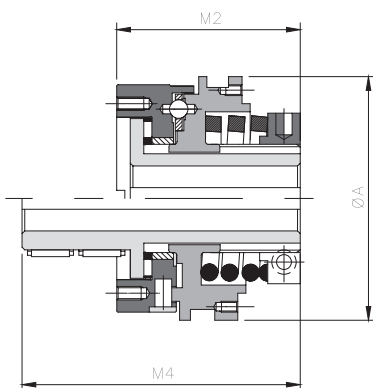

.../CM: minimum torque version

Helical springs execution, for a wider torque range and consequently a finer adjustment on calibration is possible

Size	Model	Torque [Nm]		A	M2	M4
		spring ST	spring SQ			
0.56	DSS	0,8 - 10,9	-	56	64,5	92
	DSR	1,9 - 25,6	-			
1.90	DSS	2 - 40	5 - 90	90	75	110
	DSR	8 - 75	8 - 145			
2.110	DSS	9 - 50	12 - 100	110	91	129
	DSR	12 - 90	25 - 190			
3.130	DSS	12 - 135	24 - 190	130	110	157
	DSR	30 - 300	50 - 320			

DSR - rollers torque limiter: technical data



- Basic model, connection with in-line shafts possible.
- The assembly with helical springs allows a higher sensitivity in torque setting: .../CM.
- Available with longer shaft for the assembly with transmission elements of large size : .../ML.
- Available with anti-corrosive surface treatments.
- Available with intervention signal ring.
- Torque range from 2.5 to 12.000 Nm; max. bore \varnothing 120 mm.

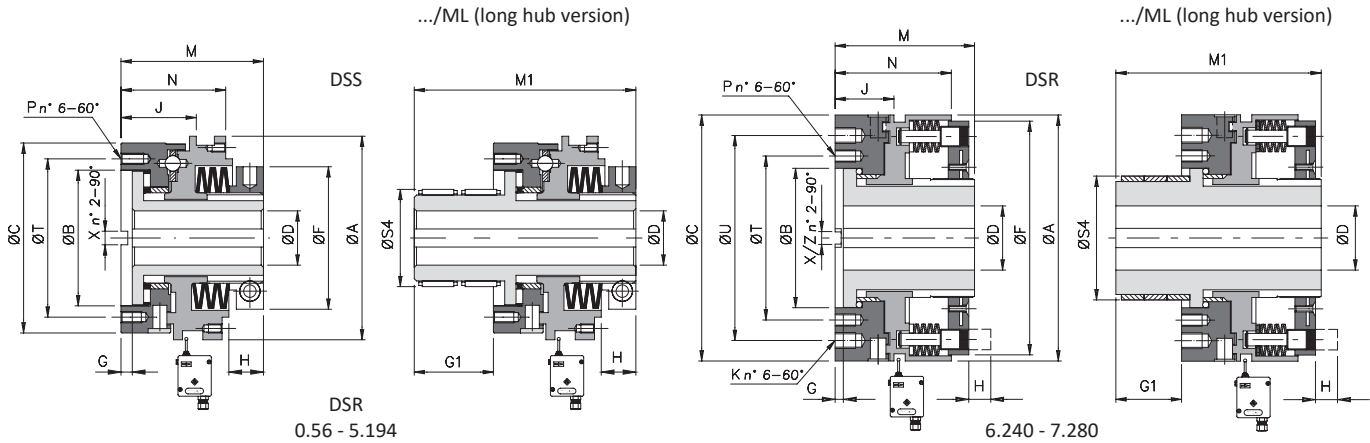

DIMENSIONS

Size	Mod.	A	B H7	C	D H7			F	G	G1	J	K	M	M1	N	P	S4 h7		T	X	U	Z
					grz	max											Bushing	Bearing				
						/ML																
0.56	DSS DSR	56	41	56	-	20	20*	42	3,8	27,5	21 20	-	46	73,5	32 31,5	M5	33	33	48	6x3	-	6x3
1.90	DSS DSR	90	60	84	-	28	28*	63	5	35	33,5 27,5	-	63	98	47 45	M5	45	43	70	6x3	-	6x3
2.110	DSS DSR	110	78	104	-	40	38	82	6	38	39 36,5	-	76	114	54 52	M6	60	55	89	8x3,5	-	8x3,5
3.130	DSS DSR	130	90,5	124	20	50	50*	104	6	47	47 45	-	88	135	65 64	M8	72	70	105	10x4	-	10x4
4.160	DSS DSR	160	105	148	25	58	58*	128	8	53	58,5 54,5	-	107	160	76,5	M10	85	83	125	12x4	-	12x4
5.194	DSS DSR	194	120,5	176	28	68	68*	157	6,5	57,5	65 64,5	-	124,5	182	88 88,5	M12	98	98	155	14x4,6	-	14x4,6
6.240	DSR	240	136	240	50	90	▲ 90	227	8	▲ 64	54,5	M16	141	▲ 205	113,5	M12	▲ 118	-	160	18x5,1	200	16x5,1
7.280	DSR	280	198	280	50	120	▲ 120	262,5	8	▲ 82	82	-	200	▲ 282	159	M20	▲ 168	-	230	20x6,1	-	20x6,1

* finished bore max diameter with reduced keyway UNI 7510.

TECHNICAL DETAILS

Size	Model	Torque [Nm]			Stroke [mm]	Inertia [kgm ²]			Max speed [Rpm]	Weight [kg]	
		T0	T1	T2		Flange side	Nut side	Nut side .../ML		DSR	.../ML
0.56	DSS DSR	2,5 - 9,5 10 - 20	5,5 - 17,5 14 - 37	15 - 32 30 - 75	1,4 1,2	0,00008	0,00010	0,00011	4500 1500	0,6	0,7
1.90	DSS DSR	20 - 49 50 - 105	25 - 65 85 - 145	35 - 115 130 - 265	2 2	0,00059	0,00106	0,00111	3000 1000	1,9	2,4
2.110	DSS DSR	19 - 72 60 - 150	55 - 160 142 - 330	80 - 290 275 - 620	3 2,5	0,00174	0,00268	0,00281	2500 800	3,6	4,4
3.130	DSS DSR	50 - 225 115 - 370	70 - 300 200 - 510	130 - 540 430 - 900	3 2,5	0,00441	0,00639	0,00686	2000 700	6,0	7,3
4.160	DSS DSR	-	150 - 690 330 - 1040	300 - 1280 750 - 1800	3,2 3	0,01067	0,01797	0,01891	1600 550	10,7	13,2
5.194	DSS DSR	-	360 - 1040 540 - 1620	460 - 2050 1050 - 2800	4,7 3	0,02873	0,04239	0,04453	1300 400	18,2	21,6
6.240	DSR	1600 - 3800	2000 - 8000	-	3,5	0,10306	0,16930	0,17371	300	30,6	▲ 38,5
7.280	DSR	2000 - 5600	2500 - 12000	-	4	0,09313	0,36412	0,39456	200	79	▲ 91,8

NOTES

▲ On request

- Weights are relevant to the pilot bore torque limiter (DSR or DSS), inertias refer to the torque limiter (DSS or DSR) hole max.
- Microswitches EM1 and inductive sensor PRX see page 69

.../FS - version with supporting flange: technical data



- Basic model with flange for parallel shafts.
- The assembly with helical springs allows a higher sensitivity in torque setting: .../FS/CM.
- Available with anti-corrosive surface treatments.
- Available with intervention signal ring.
- Available with /FAV flange for cardan coupling connection.
- Torque range from 2.5 to 12,000 Nm; max. bore $\varnothing 120$ mm.

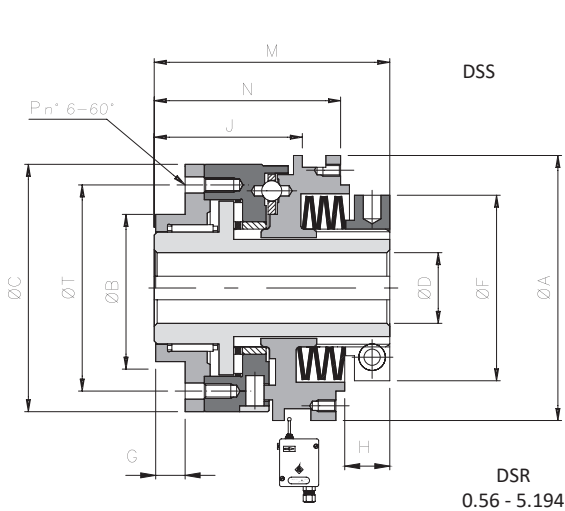

DSR
0.56 - 5.194

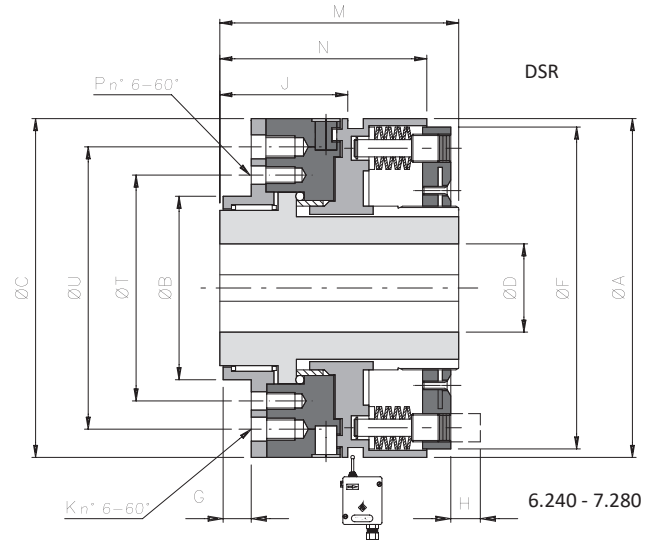

DIMENSIONS

Size	Model	A	B h7	C	D H7		F	G	J	K	M	N	P	T	U
					Pilot bore	max									
0.56	DSS DSR	56	38	56	-	20*	42	7,5	34,5 33	-	59	45 44,5	M5	48	-
1.90	DSS DSR	90	50	84	-	28*	63	9,5	50,5 44,5	-	80	64 62	M5	70	-
2.110	DSS DSR	110	60	104	-	38	82	11,5	56 53,5	-	93	71 69	M6	89	-
3.130	DSS DSR	130	80	124	20	50*	104	11,5	65 63	-	106	83 82	M8	105	-
4.160	DSS DSR	160	100	148	25	58*	128	15,5	83,5 79,5	-	132	101,5	M10	125	-
5.194	DSS DSR	194	120	176	28	68*	157	17,5	92,5 93	-	152	115,5 116	M12	155	-
6.240	DSR	240	130	240	50	90	227	18	83,5	M16	170	142,5	M12	160	200
7.280	DSR	280	190	280	50	120	262,5	30	130	-	248	207	M20	230	-

* finished bore max diameter with reduced keyway UNI 7510.

TECHNICAL DETAILS

Size	Model	Torque [Nm]			Inertia [kgm ²]		Max speed [Rpm]	Weight [kg]
		T0	T1	T2	Flange side	Nut side		
0.56	DSS DSR	2,5 - 9,5 10 - 20	5,5 - 17,5 14 - 37	15 - 32 30 - 75	0,00012	0,00010	4500 1500	0,7
1.90	DSS DSR	20 - 49 50 - 105	25 - 65 85 - 145	35 - 115 130 - 265	0,00087	0,00109	3000 1000	2,4
2.110	DSS DSR	19 - 72 60 - 150	55 - 160 142 - 330	80 - 290 275 - 620	0,00234	0,00275	2500 800	4,4
3.130	DSS DSR	50 - 225 115 - 370	70 - 300 200 - 510	130 - 540 430 - 900	0,00575	0,00660	2000 700	7,1
4.160	DSS DSR	-	150 - 690 330 - 1040	300 - 1280 750 - 1800	0,01447	0,01848	1600 550	13
5.194	DSS DSR	-	360 - 1040 540 - 1620	460 - 2050 1050 - 2800	0,03664	0,04352	1300 400	21,6
6.240	DSR	1600 - 3800	2000 - 8000	-	0,13005	0,17123	300	37,5
7.280	DSR	2000 - 5600	2500 - 12000	-	0,18058	0,38306	200	90,5

NOTES

- Weights are relevant to the pilot bore torque limiter (.../FS), inertias refer to the torque limiter (.../FS) hole max.
- Microswitches EM1 and inductive sensor PRX see page 69

... + GTR - model with torsionally rigid coupling: technical data

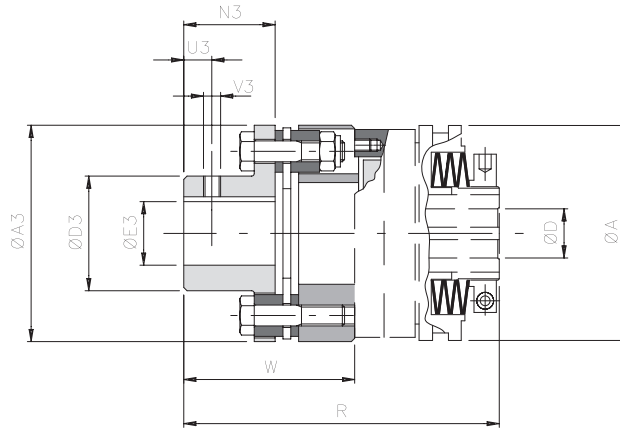

DIMENSIONS AND TECHNICAL DETAILS

Size		Torque [Nm]		A3	D3	E3 H7 max	N3	U3	V3	A	D H7		R	W	Misalignments			Rigidity [Nm/rad*10 ³]	Max speed [Rpm]		Weight [Kg]
DSS	DSR	Nom	Max								Pilot bore	max			Angular α [°]	Axial X [mm]	Radial K [mm]		DSS	DSR	
0.56	0	60	120	78	45	32	29	10	M5	56	-	20	105	59	1°	0,7	0	80	4500	1500	1,4
1.90	2	150	300	92	53	38	42	10	M5	90	-	28	137	74	0° 45'	0,9		156	3000	1000	2,1
2.110	3	300	600	112	65	45	46	15	M8	110	-	40	161	85	0° 45'	1,2		415	2500	800	3,9
3.130	4	700	1400	136	75	52	56	15	M8	130	20	50	186	98	0° 45'	1,4		970	2000	700	5,8
4.160	5	1100	2200	162	92	65	66	20	M8	160	25	58	223	116,5	0° 45'	1,6		1846	1600	550	10,8
5.194	7	2600	5200	206	130	90	92	20	M10	194	28	68	270	145,5	0° 45'	2,2		3511	1300	400	21,9

... + GAS - model with jaw coupling: technical data

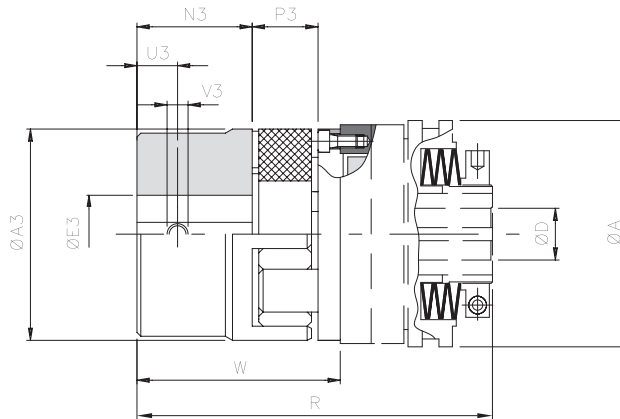

DIMENSIONS AND TECHNICAL DETAILS

Size		Torque [Nm]		A3	E3 H7 max	N3	P3	U3	V3	A	D H7		R	W	Misalignments			Max speed [Rpm]		Weight [Kg]		
DSS	DSR	GAS									Pilot bore	max			Angular α [°]	Axial X [mm]	Radial K [mm]	DSS	DSR			
		Std	▲ min																			
0.56	0 (24)	00 (19)		60	120	55	35	30	18	10	M5	56	-	20	103	57	1° 18'	-0,5/+1,4	0,22	4500	1500	0,8
1.90	2 (38)	0 (24)		325	650	80	48	45	24	15	M8	90	-	28	141	78		-0,7/+1,8	0,28	3000	1000	3,7
2.110	4 (48)	1 (28)		525	1050	105	62	56	28	20	M8	110	-	40	171	95		-1/+2,1	0,36	2500	800	5,2
3.130	5 (55)	2 (38)		685	1370	120	74	65	30	20	M10	130	20	50	198	110		-1/+2,2	0,38	2000	700	9,1
4.160	7 (74)	4 (48)		1465	2930	160	95	85	40	25	M10	160	25	58	249	142		-1,5/+3	0,48	1600	550	17,9
5.194	8 (90)	5 (55)		3600	7200	200	110	100	45	30	M12	194	28	68	288,5	164		-1,5/+3,4	0,50	1300	400	29,5
▲ 6.240	9 (100)	-		4900	9800	225	120	110	50	30	M12	240	50	90	326	185		-1,5/+3,8	0,52	-	300	-
▲ 7.280	10 (110)	-		7000	14000	255	130	120	55	33	M16	280	50	120	418	212	-2/+4,2	0,55	-	200	-	

▲ On request

NOTES

- Data is relevant only to application (GTR - GAS), for torque limiter data see on page 23.
- Weights are relevant to the pilot bore torque limiter (GTR - GAS).
- Microswitches EM1 and inductive sensor PRX see page 69

... + GEC - model with compact elastic coupling: technical data

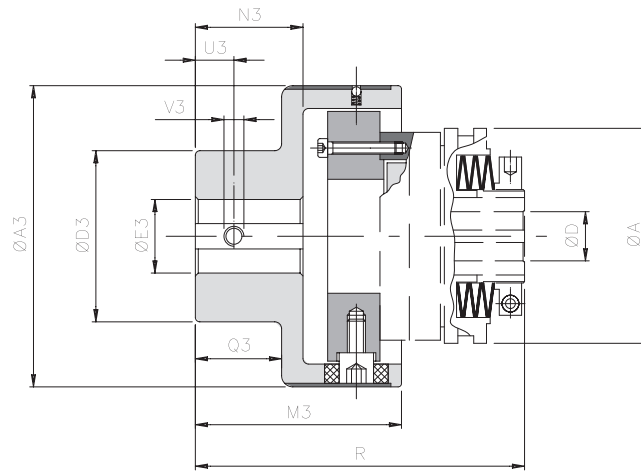

DIMENSIONS

Size		Torque [Nm]		A3	D3	E3 H7		M3	N3	Q3	U3	V3	A	D H7		R
DSS - DSR	GEC	Nom	Max			pilot bore	max							pilot bore	max	
0.56	0	70	110	78	50	-	28	63,5	32	28	8	M4	56	-	20	100,5
1.90	1	280	420	108	70	-	38	89	49	44	12	M6	90	-	28	142
2.110	2	570	860	130	80	-	45	111	65	59	15	M8	110	-	40	177
3.130	3	980	1500	161	100	-	60	140	85	77	15	M8	130	20	50	215
4.160	4	2340	3600	206	120	20	70	168	105	97	20	M10	160	25	58	261
5.194	5	3880	5800	239	135	30	80	201	130	120	20	M10	194	28	68	309,5
6.240	6	15000	20000	315	215	40	150	260	165	150	25	M12	240	50	90	381
7.280	7	15000	17500	364	240	40	180	310	205	185	25	M12	280	50	120	485

TECHNICAL DETAILS

Size		Misalignments						Max speed [Rpm]		Weight [kg]
DSS DSR	GEC	Angular α [°]		Axial X [mm]		Radial K [mm]		DSS	DSR	
		continuous	intermittent	continuous	intermittent	continuous	intermittent			
0.56	0	1°	1° 30'	± 0,7	± 1,5	0,5	0,7	4500	1500	1,2
1.90	1	0° 48'	1°	± 0,7	± 1,5	0,5	0,7	3000	1000	3,5
2.110	2	0° 36'	0° 48'	± 0,7	± 1,5	0,6	0,7	2500	800	6,2
3.130	3	0° 30'	0° 42'	± 0,8	± 1,6	0,6	0,8	2000	700	11,5
4.160	4	0° 24'	0° 30'	± 0,8	± 1,6	0,6	0,8	1600	550	20,8
5.194	5	0° 24'	0° 30'	± 0,8	± 1,6	0,6	0,8	1300	400	32
6.240	6	0° 24'	0° 30'	± 0,8	± 1,6	0,6	0,8	-	300	91,3
7.280	7	0° 24'	0° 30'	± 0,8	± 1,6	0,6	0,8	-	200	173,9

▲ On request

NOTES

- Data is relevant only to application (GEC), for torque limiter data see on page 23.
- Weights are relevant to the pilot bore torque limiter (GEC).
- Microswitches EM1 and inductive sensor PRX see page 69

DSR - rollers torque limiter: versions on request

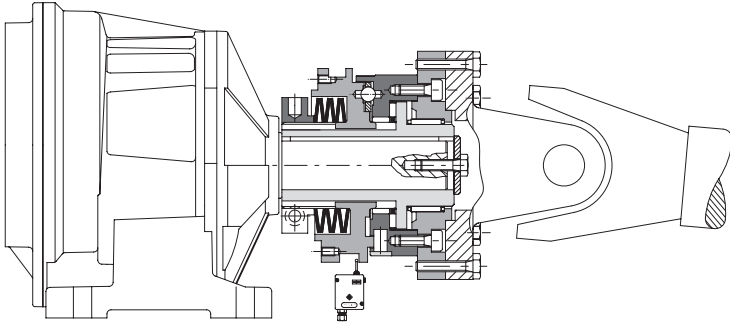

.../FAV

Flange designed and arranged for the connection of the cardan shafts, supported by the cage and rollers.

DSR - rollers torque limiter: additional information

ORDER EXAMPLE

ROLLERS TORQUE LIMITER				
Size	Model	.../Version	Finished bore	Torque/Springs
2.110	DSR/F	-	d=30 H7	350 Nm

+

COUPLING			
Model	Elastomeric element	Finished bore	Hub connection
GAS	Normal red element 98 Sh-A	dz=38 H7	A1

Size
da 0.56 a 7.280

Springs

T0
T1
T2

Model

DSR	Roller torque limiter
DSR/F	Roller phase torque limiter
DSS	Ball torque limiter

Version

-	base version
.../ML	with long hub
.../FS	with supporting flange
.../CM	with helical springs
.../SMO	with one-way rotation
.../AM	with mechanical stop
.../TAS	with stops pin

Model

GTR	Torsionally rigid disc coupling
GAS	Elastic jaw coupling
GEC	Compact elastic coupling

Locking type

See hub connection type list on page 4