

KETTENGLEITER TYP CR/CRS/CRD

CHAIN RIDER TYPE CR/CRS/CRD

CR



CRS



CRD



RESATEC KETTENGLEITER TYP CR/CRS/CRD:

Für die Spannung von Ketten mit geringer Laufgeschwindigkeit (Dauerbetrieb bis 1,5 m/s) kann der Kettengleiter Typ CR eingesetzt werden. Der hochwertige Kunststoff kommt ohne jegliche Schmierung aus. Durch die einzigartige Formgebung umschließt die Kette den Gleiter immer so, dass eine problemlose Führung der Kette gewährleistet wird. Typ CRS bzw. CRD wird als Set mit dem passenden Befestigungsmaterial zum entsprechenden Spannelement mitgeliefert.

RESATEC CHAIN RIDER TYPE CR/CRS/CRD:

For the tensioning of chains with low running speed (continuous operation up to 1.5 m/s) the chain rider type CR can be used. The high quality plastic material does not require any lubrication. Due to the unique design, the chain always encloses the rider in such a way that problem-free guiding of the chain is ensured. Type CRS or CRD is supplied as a set with the appropriate assembly material for the corresponding tensioning element.

**PASSEND ZU ALLEN TE-TYPEN
SEITE 42/44**



**MATCHING ALL
TE-TYPES
PAGE 42/44**

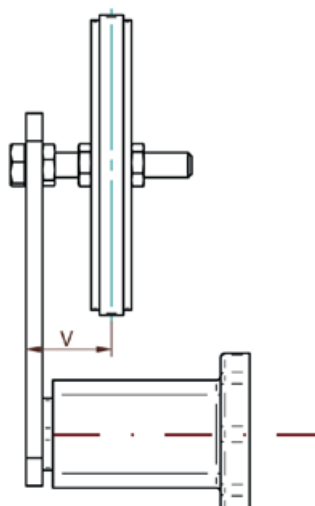
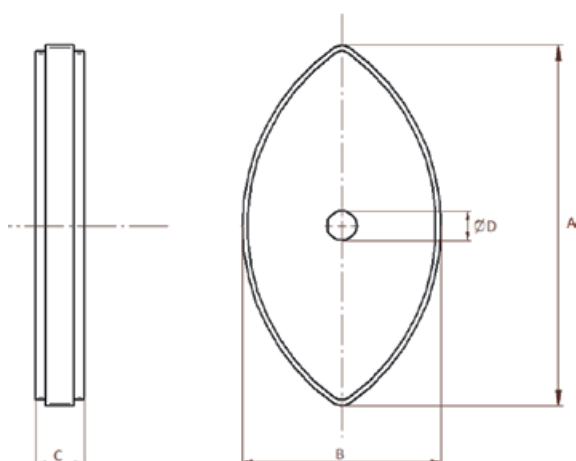

Typ type	Art. Nr. art. no.	Rollenkette roller chain	ANSI					Schraube screw	6kt-Mutter hex-nut 3Stk/pcs	Anzieh- moment torque	passend zu suitable for	Einstellbereich adjusting range	Gewicht weight
			C	A	B	øD	V						
		DIN 8187								Nm	Typ/type		
CR 3/8" -8	553 000 10	ISO-06 B	35	10.2	74	40	8	–	–	–	–	–	0.02
CR 1/2" -10	553 000 11	ISO-08 B	40	13.9	96	50	10	–	–	–	–	–	0.05
CR 5/8" -10	553 000 12	ISO-10 B	50	16.5	125	55	10	–	–	–	–	–	0.08
CR 3/4" -12	553 000 13	ISO-12 B	60	19.5	147	80	12	–	–	–	–	–	0.12
CRS 3/8" S	553 001 10	ISO-06 B-1	35	10.2	74	40	–	M8×45	M8 – 0.5d	10	TE 3	21 – 34	0.05
CRS 1/2" S	553 001 11	ISO-08 B-1	40	13.9	96	50	–	M10×60	M10 – 0.5d	20	TE 3/TE 4	23 – 47/24 – 47	0.11
CRS 5/8" S	553 001 12	ISO-10 B-1	50	16.5	125	55	–	M10×60	M10 – 0.5d	20	TE 4	25 – 48	0.14
CRS 3/4" S	553 001 13	ISO-12 B-1	60	19.5	147	80	–	M12×80	M12 – 0.5d	35	TE 5	29 – 64	0.22
CRS 3/8" D	553 002 10	ISO-06 B-2	35	10.2	74	40	–	M8×45	M8 – 0.5d	10	TE 3	26 – 29	0.07
CRS 1/2" D	553 002 11	ISO-08 B-2	40	13.9	96	50	–	M10×60	M10 – 0.5d	20	TE 3/TE 4	30 – 40/31 – 40	0.12
CRS 5/8" D	553 002 12	ISO-10 B-2	50	16.5	125	55	–	M10×60	M10 – 0.5d	20	TE 4	34 – 47	0.17
CRS 3/4" D	553 002 13	ISO-12 B-2	60	19.5	147	80	–	M12×80	M12 – 0.5d	35	TE 5	39 – 54	0.26
CRS-I 3/8" S	553 101 10	ISO-06 B-1	35	10.2	74	40	–	M8×45	M8 – 0.5d	10	TE-I 3	21 – 34	0.05
CRS-I 1/2" S	553 101 11	ISO-08 B-1	40	13.9	96	50	–	M10×60	M10 – 0.5d	20	TE-I 3/TE-I 4	23 – 47/24 – 47	0.11
CRS-I 5/8" S	553 101 12	ISO-10 B-1	50	16.5	125	55	–	M10×60	M10 – 0.5d	20	TE-I 4	25 – 48	0.14
CRS-I 3/4" S	553 101 13	ISO-12 B-1	60	19.5	147	80	–	M12×80	M12 – 0.5d	35	TE-I 5	29 – 64	0.22
CRS-I 3/8" D	553 102 10	ISO-06 B-2	35	10.2	74	40	–	M8×45	M8 – 0.5d	10	TE-I 3	26 – 29	0.07
CRS-I 1/2" D	553 102 11	ISO-08 B-2	40	13.9	96	50	–	M10×60	M10 – 0.5d	20	TE-I 3/TE-I 4	30 – 40/31 – 40	0.12
CRS-I 5/8" D	553 102 12	ISO-10 B-2	50	16.5	125	55	–	M10×70	M10 – 0.5d	20	TE-I 4	34 – 47	0.17
CRS-I 3/4" D	553 102 13	ISO-12 B-2	60	19.5	147	80	–	M12×80	M12 – 0.5d	35	TE-I 5	39 – 54	0.26

Material

Gleiter CR aus Vesconite®

Temperaturbereich –40°C bis 120°C

max. Reibungswärme 240°C

max. Kettengeschwindigkeit 1,5 m/s

Schraube DIN 933 ISO 4017 Stahl 8,8 galvanisch verzinkt

CRS-I Schraube DIN 933 ISO 4017 A2

6kt-Mutter DIN 439 B ISO 4035 Stahl 8,8 galvanisch verzinkt

CRS-I 6kt-Mutter DIN 439 B ISO 4035 A2

In Ex-Schutzräumen empfehlen wir die Komponenten zu erden

Typ CRS S verpackt mit Heissfolie auf Karton

andere Typen lose verpackt

Material

Glider CR made in Vesconite®

temperature range –40°C until 120°C

max. frictional head 240°C

max. chain speed limit 1.5 m/s

screw DIN 933 ISO 4017 steel 8.8 galvanised

CRS-I screw DIN 933 ISO 4017 A2

hex-nut DIN 439 B ISO 4035 steel 8.8 galvanised

CRS-I hex-nut DIN 439 B ISO 4035 A2

in Ex-shelters the components have to be grounded

type CRS S are skinpacked on cardboard

the other types components are loosely packed



RESATEC AG
ROSENWEG 1
CH-5037 MUHEN

+41 62 723 27 24
INFO@RESATEC.CH
WWW.RESATEC.CH

