





LINEAR SLIDES

Linear Slides | Product Overview | DIRECTCONNECT™ Mounting

Model	Stroke mm [in]	Thrust Force N [lbs]	Operating Environment	Special Features	Page GR-LIN-#
DLB 	6-500 [0.25-26]	89-560 [20-126]	IP54	High Reliability with smooth operation base slide. Internal or external air cylinder options. DIRECTCONNECT	3
DLT 	6-700 [0.25-28]	89-560 [20-126]	IP54	High Reliability with smooth operation Thrust slide. Internal or external air cylinder options. DIRECTCONNECT	17
DLM 	5-100 [0.2-4]	67-230 [15-52]	IP54	Precise positioning with stroke adjustments. High load and moment capacity. DIRECTCONNECT	37
MPS 	13-51 [0.5-2]	67-196 [15-44]	IP54	Compact slide with zero side play. Dual-V bearing design. Adjustable stops.	43

DIRECTCONNECT Modular Direct Mounting System without Adapter Plates

Products can be mounted in multiple positions. Refer to datasheet for complete info.

Slide to Slide

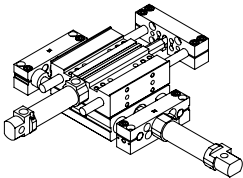

DLB Base Slide to DLT Thruster Slide

Slide to Slide

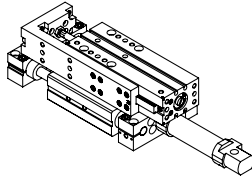

DLB Base Slide to DLM Thruster Slide

Slide to Gripper

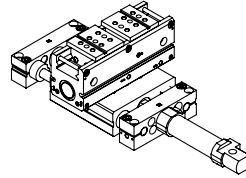

DLB Base Slide to DPG Parallel Gripper

Slide to Rotary

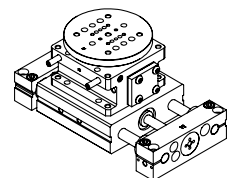

DLB Base Slide to DRF Rotary Actuator

Slide to Slide

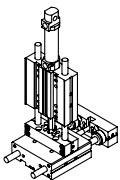

DLT Thruster Slide to DLT Thruster Slide

Slide to Slide

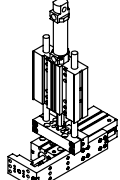

DLT Thruster Slide to DLM Thruster Slide

Slide to Gripper

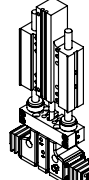

DLT Thruster Slide to DPDL Parallel Gripper

Slide to Rotary

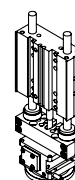

DLT Thruster Slide to DRF Rotary Actuator

Slide to Slide

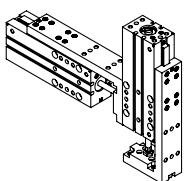

DLM Thruster Slide to DLM Thruster Slide

Slide to Slide

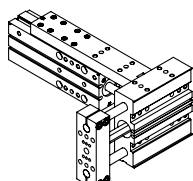

DLM Thruster Slide to DLT Thruster Slide

Slide to Gripper

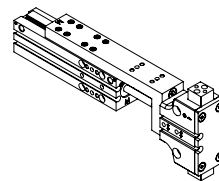

DLM Thruster Slide to DPDL Parallel Gripper

Slide to Rotary

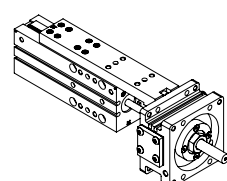

DLM Thruster Slide to DRG Rotary Actuator

LINEAR SLIDES

Linear Slides | DIRECTCONNECT™ Mounting Compatibility Chart

DESTACO's DIRECTCONNECT™ technology, allows all components of the system—grippers, rotaries and slides—to be mounted together directly. Look for matching icons on product datasheets for mounting compatibility.

Note: The numbers in the cell represent the metric screw size and basic mounting pattern.

S=Square, R=Rectangle. ie; 5S = M5 Screw with square mounting pattern.

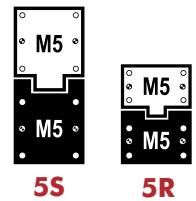

Catalog Models		Base Slides			Thruster Slides				
		DLB-06&08	DLB-10,12,16	DLB-20&25	DLT-06&08	DLT-10,12,16	DLT-20&25	DLM-07	DLM-09&12
Base Slides	DLB-06,08				3R,3S			3R,3S	
	DLB-10,12,16				3S	5R,5S		3S	5R,5S
	DLB-20,25					5S	10R,10S		5S
Thruster Slides	DLT-06,08	3R,3S	3S		3R	3R		3R	3R
	DLT-10,12,16		5R,5S	5S		5R	5R		5R
	DLT-20,25			10R,10S			10R		
	DLM-07	3R,3S	3S		3R	3R		3R	3R
	DLM-9,12		5R,5S	5S		5R	5R		5R
Rotary Actuators	DRF-075,094		5R			5R	5R		5R
	DRF-106		5R	10R		5R	10R		5R
	DRF-131		5R	10R		5R	10R		5R
	DRG-074,094		5R			5R	5R		5R
	DRG-106		5R	10R		5R	10R		5R
	DRG-131		5R	10R		5R	10R		5R
Grippers	DGC		5R			5R	5R		5R
	DPG		5R			5R	5R		5R
	DCT-12, 16,25	3R			3R	3R		3R	3R
	DCT-25		5R			5R	5R		5R
	DPDL-047,056	3R			3R	3R		3R	3R
	DPDL-088,125		5R			5R	5R		5R
	DPDL-175,250			10R			10R		
	DPDS-047,056	3R			3R	3R		3R	3R
	DPDS-088,125		5R			5R	5R		5R
	DPDS-175,250			10R			10R		
	DPL-25xx		5R			5R	5R		5R
	DPL-32xx,40xx			10R			10R		
	DPP-10,14	3R			3R	3R		3R	3R
	DPP-20		5R			5R	5R		5R
	DPP-28		5R	10R		5R	10R		5R
	DPW-250	3R			3R	3R		3R	3R
	DPW-375,500		5R			5R	5R		5R
	G100-08,011	3R			3R	3R		3R	3R
	G100-18,25		5R			5R	5R		5R
	DPE-200		5R			5R	5R		5R
DPE-400			10R			10R			

DLB SERIES - INTERNAL AIR CYLINDER

Internal Air Cylinder Linear Base Slides | Features and Benefits | How To Order

Features:

- Bearing system for smooth operation
- Rugged design produces very reliable long life operation
- Internal air cylinder for space-limited applications
- Telescopic airlines, shocks and hard stops available
- Viton® seals for high temp applications
- Corrosion resistant shafting for corrosive environments
- Inductive sensing for position detection
- Custom stroke lengths available.

Applications:

- Machining and automation applications
- Harsh environment pick-and-place applications
- OEM machines

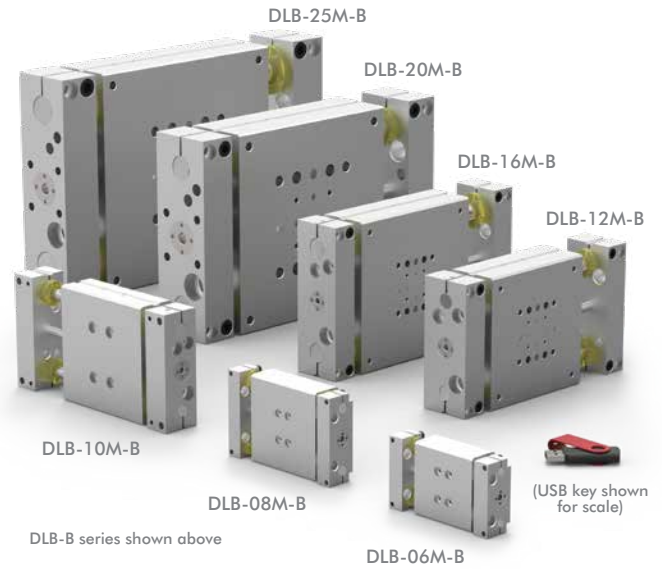

How To Order

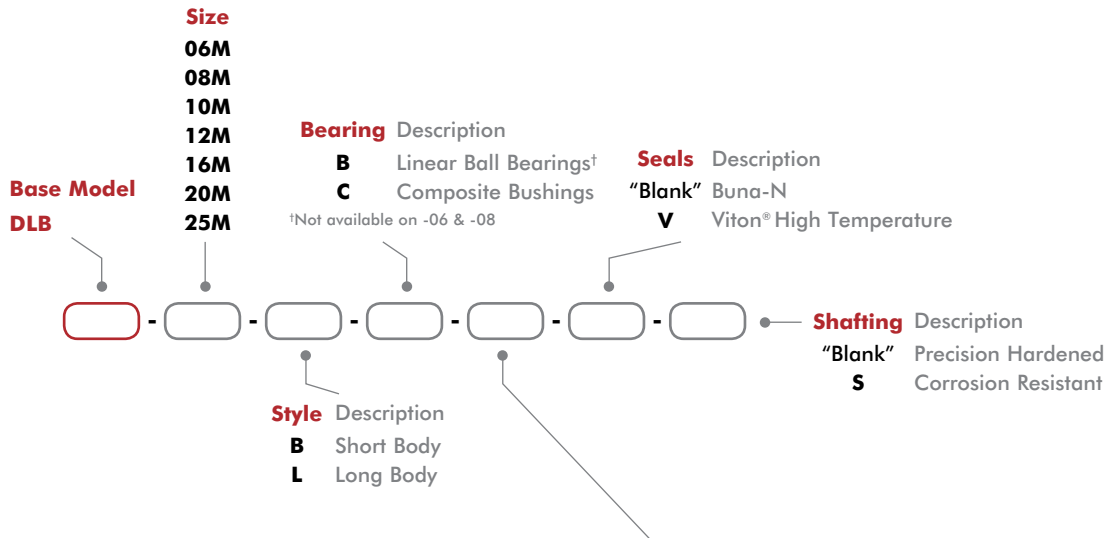

-B Style	Stroke* Metric (mm)
DLB-06M-B	6, 12, 25, 30
DLB-08M-B	6, 12, 25, 40, 44
DLB-10M-B	25, 50
DLB-12M-B	25, 50
DLB-16M-B	25, 50, 80
DLB-20M-B	25, 50, 80, 100
DLB-25M-B	25, 50, 80, 100, 125

-L Style	Stroke* Metric (mm)
DLB-06M-L	12, 25, 40, 50, 65, 75
DLB-08M-L	12, 25, 40, 50, 65, 75, 85
DLB-10M-L	25, 50, 80, 100
DLB-12M-L	25, 50, 80, 100, 125
DLB-16M-L	25, 50, 80, 100, 125, 150
DLB-20M-L	25, 50, 80, 100, 125, 160
DLB-25M-L	25, 50, 80, 100, 125, 160, 175

*Custom strokes available. Consult factory.

*Custom strokes available. Consult factory.

DLB SERIES - INTERNAL AIR CYLINDER

Internal Air Cylinder Linear Base Slides | Accessories and Technical Specifications

Shock/Stop Accessories	Model Numbers	Style	Part Number	Qty/Unit	
Shock Absorber	06, 08	ALL	SHOK-030	1-2	
	10		SHOK-028		
	12, 16,		SHOK-010		
	20, -25		SHOK-029		
Adjustable Hard Stop	06, 08	ALL	DLT-0623	1-2	
	10, 12, 16, 20, 25		DLT-1023		
Sensor Accessories	Model Numbers	Style	Part Number	Qty/Unit	
PNP Inductive Sensor with Quick Disconnect*	All Models	ALL	OISP-011	1-2	
NPN Inductive Sensor with Quick Disconnect*			OISN-011		
Quick Disconnect 2 Meter Cable Length*			CABL-010		
Quick Disconnect 5 Meter Cable Length*			CABL-013		
Pneumatic Accessories	Model Numbers	Style	Part Number	Qty/Unit	
G1/8 Telescopic Airlines (up to 50mm)	10, 12, 16	B	OTAL-043	1-4	
G1/8 Telescopic Airlines (up to 80mm)	10, 12, 16		OTAL-044		
G1/8 Telescopic Airlines (up to 100mm)	10, 12, 16	L	OTAL-051		
G1/8 Telescopic Airlines (up to 125mm)	10, 12, 16		OTAL-052		
G1/8 Telescopic Airlines (up to 160mm)	10, 12, 16, 20, 25	L	OTAL-045	1-2	
G1/8 Telescopic Airlines (up to 300mm)	20, 25		OTAL-046		
M5 Adjustable Flow Control	06, 08, 10, 12, 16	ALL	VLVF-008		1-2
G 1/8 Adjustable Flow Control	20, 25		VLVF-005		
Cylinder Seal Kit (Buna-N)	06, 08		ALL	SLKT-109	1
	10			SLKT-101	
	12, 16	SLKT-103			
	20, 25	SLKT-105			
Cylinder Seal Kit (Viton®)	06, 08	ALL	SLKT-109V		
	10		SLKT-101V		
	12, 16		SLKT-103V		
	20, 25		SLKT-105V		

* Sensor and cable sold separately.

See page GR-LIN-35 for Accessory Mounting Technical Data.

Specifications

Specifications	Units	06-B, L	08-B, L	10-B, L	12-B, L
Max. Air Pressure	bar [psi]	7 [100]			
Thrust Force @ 5.5 bar [80psi]	N [lbs]	89 [20]		129 [29]	254 [57]
Weight (basic unit) -B	kg [lb]	0.20 [0.44]	0.36 [0.79]	0.93 [2.08]	1.7 [3.83]
Weight (basic unit) -L	kg [lb]	0.32 [0.71]	0.56 [1.24]	1.50 [3.34]	2.30 [5.13]
Additional Weight per Stroke -B	g/mm [lbs/in]	0.53 [0.03]	0.88 [0.05]	1.4 [0.08]	2.1 [0.12]
Cylinder Bore Ø	mm [in]	14.29 [0.563]		19 [0.75]	25 [1.00]
Shaft Ø	mm [in]	6 [0.236]	8 [0.315]	9.5 [0.375]	12 [0.472]

Specifications	Units	16-B, L	20-B, L	25-B, L
Max. Air Pressure	bar [psi]	7 [100]		
Thrust Force @ 5.5 bar [80psi]	N [lbs]	254 [57]	560 [126]	560 [126]
Weight (basic unit) -B	kg [lb]	2.4 [5.19]	5.9 [13.0]	8.2 [18.2]
Weight (basic unit) -L	kg [lb]	3.30 [7.30]	7.1 [15.6]	9.7 [21.4]
Additional Weight per Stroke -B	g/mm [lbs/in]	3.3 [0.19]	5.54 [0.32]	8.4 [0.47]
Cylinder Bore Ø	mm [in]	25 [1.00]	38 [1.5]	38 [1.5]
Shaft Ø	mm [in]	16 [0.630]	20 [0.787]	25 [0.984]

DLB-06/08M-B



Internal Air Cylinder Linear Base Slides | Dimensions and Technical Specifications

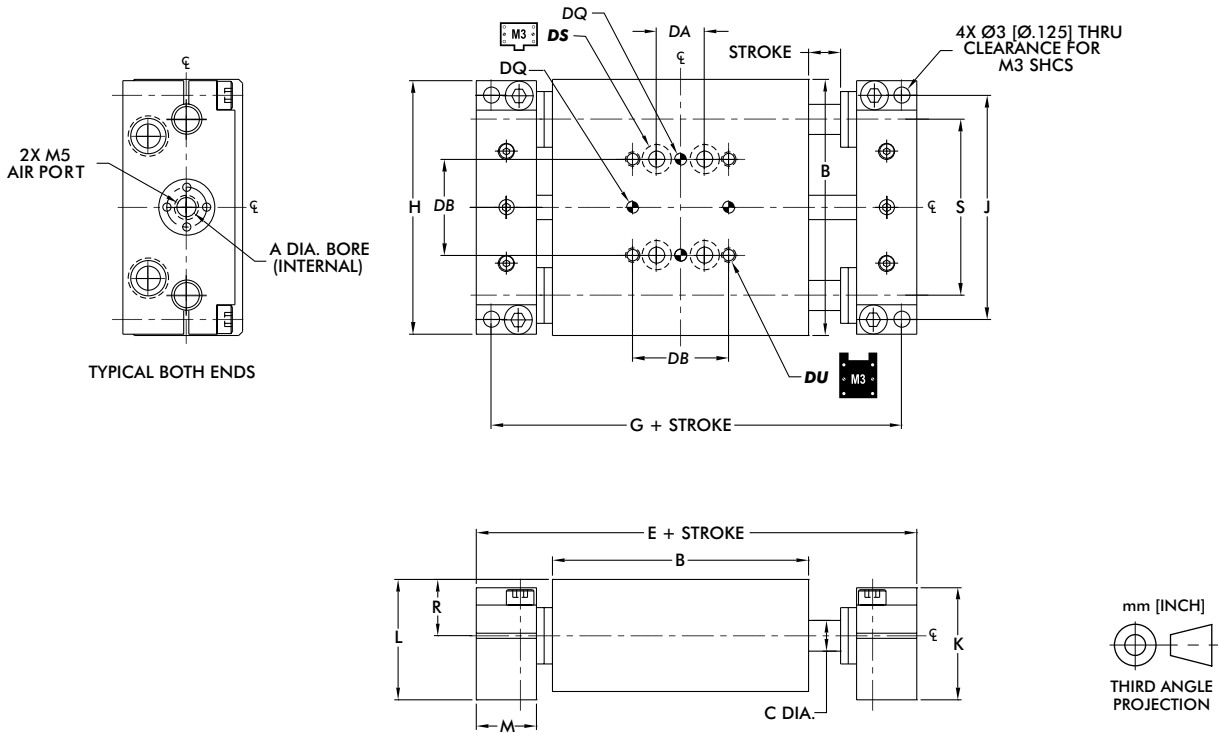

mm [INCH]
THIRD ANGLE PROJECTION

DIRECTCONNECT™ Mounting Pattern Dimensions (all sizes)

DA	DB	DQ	DS	DU
9.5 [0.375]	19.1 [0.750]	3H7 X 2 DP	CLR & C'BORE FOR M3	M3 x 6 DP

Model	Bore Ø	Body Size	Shaft Ø	Basic Unit Dimensions								
				A	B	C	E	G	H	J	K	L
DLB-06M	14 [0.563]	50.8 [2.000]	6.0 [0.236]	81.0 [3.19]	75.1 [2.956]	50.3 [1.980]	44.4 [1.750]	22.2 [0.875]	23.7 [0.936]	11.9 [0.470]	11.13 [0.438]	34.93 [1.375]
DLB-08M		63.5 [2.500]	8.0 [0.315]	93.7 [3.69]	87.8 [3.456]	62.7 [2.470]	57.1 [2.250]					44.45 [1.750]

Dimensions in mm [in]

Loading Information

- F**=Externally applied force
- W**=Weight of payload
- F+W**=Total force
- M**=Maximum moment

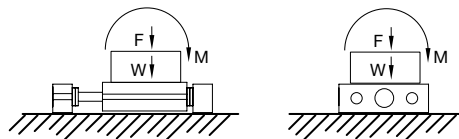

	06	08
Maximum Payload (W) horizontal motion using Shock Absorbers	1.4 kg [3 lbs]	2.3 kg [5 lbs]
Maximum Payload (W) vertical motion using Shock Absorbers	0.7 kg [1.5 lbs]	1.1 kg [2.5 lbs]
Maximum Payload (W) horizontal motion using Urethane Bumpers	0.5 kg [1 lbs]	0.5 kg [1 lbs]
Maximum Total Applied Load + Payload (F+W)	45 N [10 lbs]	53.4 N [12 lbs]
Total Maximum Moment about any Axis (M)	1.7 Nm [15 in-lbs]	3.4 Nm [30 in-lbs]

Shock Absorbers and Flow Controls are recommended for all applications

Internal Air Cylinder Linear Base Slides | Dimensions and Technical Specifications

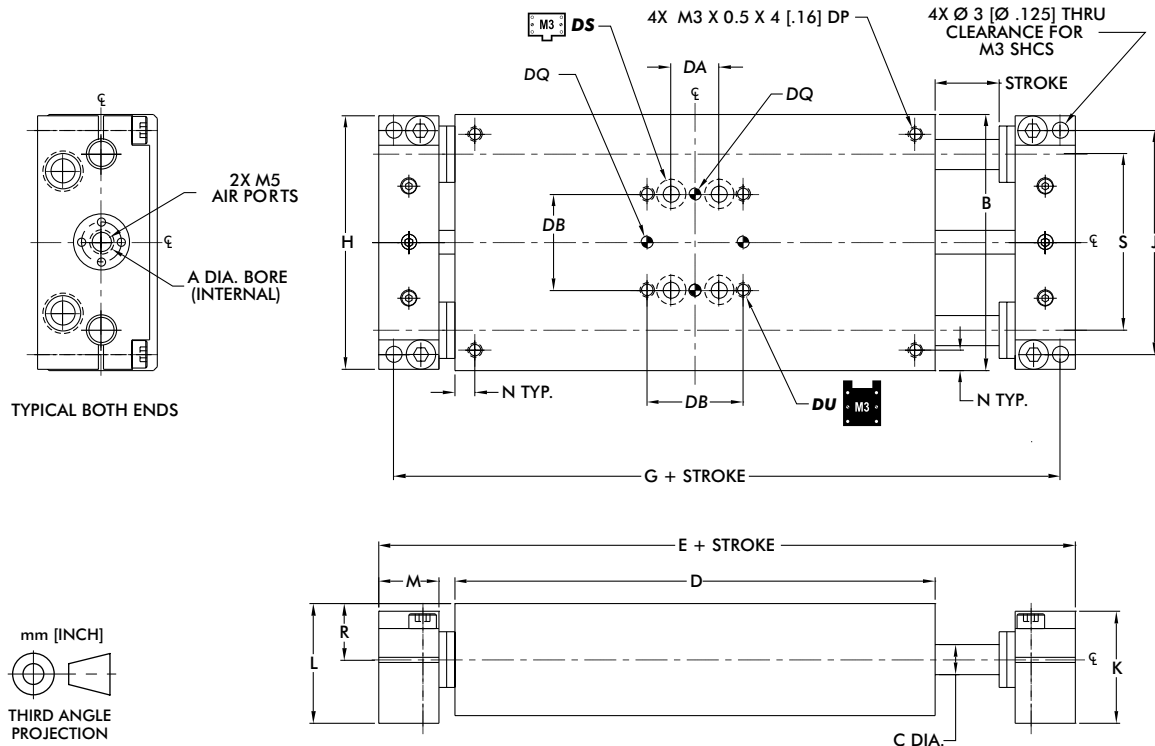

DIRECTCONNECT™ Mounting Pattern Dimensions (all sizes)

DA	DB	DQ	DS	DU
9.5 [0.375]	19.1 [0.750]	3H7 X 2 DP	CLR & C'BORE FOR M3	M3 X 6 DP

Model	Bore Ø	Body Size	Shaft Ø	Basic Unit Dimensions										
				A	B	C	D	E	G	H	J	K	L	M
DLB-06M	14 [0.563]	50.8 [2.00]	6.0 [0.236]	95.2 [3.75]	125.5 [4.94]	119.6 [4.71]	50.3 [1.980]	44.4 [1.750]	22.2 [0.875]	23.7 [0.936]	11.9 [0.470]	3.96 [0.156]	11.13 [0.438]	34.93 [1.375]
DLB-08M		63.5 [2.50]	8.0 [0.315]	107.9 [4.25]	138.2 [5.44]	132.2 [5.206]	62.7 [2.470]	57.1 [2.250]						44.45 [1.750]

Dimensions in mm [in]

Loading Information

- F=Externally applied force
- W=Weight of payload
- F+W=Total force
- M=Maximum moment

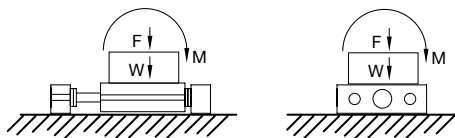

	06	08
Maximum Payload (W) horizontal motion using Shock Absorbers	1.4 kg [3 lbs]	2.3 kg [5 lbs]
Maximum Payload (W) vertical motion using Shock Absorbers	0.7 kg [1.5 lbs]	1.1 kg [2.5 lbs]
Maximum Payload (W) horizontal motion using Urethane Bumpers	0.5 kg [1 lbs]	0.5 kg [1 lbs]
Maximum Total Applied Load + Payload (F+W)	45 N [10 lbs]	53.4 N [12 lbs]
Total Maximum Moment about any Axis (M)	1.7 Nm [15 in-lbs]	3.4 Nm [30 in-lbs]

Shock Absorbers and Flow Controls are recommended for all applications

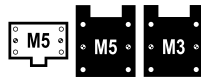

Internal Air Cylinder Linear Base Slides | Dimensions and Technical Specifications

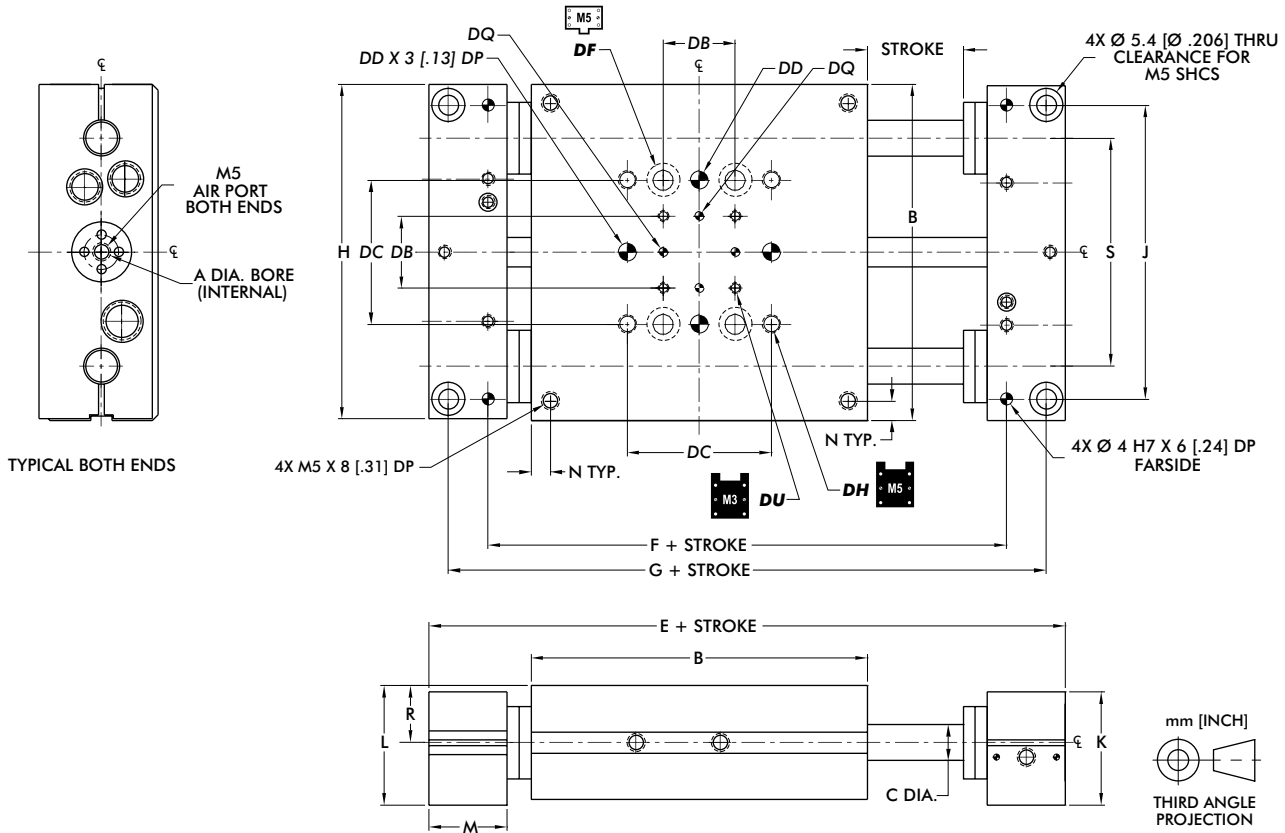

DIRECTCONNECT™ Mounting Pattern Dimensions (all sizes)

DB	DC	DD	DF	DH	DQ	DU
19.1 [0.750]	38.1 [1.500]	5mm H7 X 6 DP	CLEARANCE FOR M5	M5 X 8.5DP	3H7 X 2 DP	M3 X 6 DP

Model	Bore Ø			Basic Unit Dimensions										
	A	B	C	E	F	G	H	J	K	L	M	N	R	S
DLB-10M	19 [0.75]	88.9 [3.50]	9.5 [0.375]	143.0 [5.63]	111.70 [4.3975]	132.8 [5.228]	88.5 [3.485]	77.72 [3.0600]	29.9 [1.178]	31.6 [1.245]		N/A	15.09 [0.594]	60.33 [2.375]
DLB-12M	25 [1.00]	101.6 [4.00]	12 [0.472]	155.7 [6.13]	124.40 [4.8975]	145.5 [5.728]	101.2 [3.985]	88.90 [3.5000]	41.0 [1.615]	42.1 [1.657]	20.7 [0.813]	9.5 [0.375]	20.65 [0.813]	69.85 [2.750]
DLB-16M		120.7 [4.75]	16 [0.630]	174.8 [6.88]	143.45 [5.6475]	164.5 [6.478]	120.3 [4.735]	107.95 [4.2500]						

Dimensions in mm [in]

Loading Information

- F=Externally applied force
- W=Weight of payload
- F+W=Total force
- M=Maximum moment

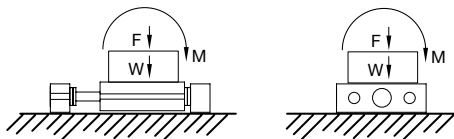

	10	12	16
Maximum Payload (W) horizontal motion using Shock Absorbers	6.8 kg [15 lbs]	13.6 kg [30 lbs]	20.4 kg [45 lbs]
Maximum Payload (W) vertical motion using Shock Absorbers	3.1 kg [7 lbs]	6.8 kg [15 lbs]	9.9 kg [22 lbs]
Maximum Payload (W) horizontal motion using Urethane Bumpers	2.2 kg [5 lbs]	4.5 kg [10 lbs]	6.8 kg [15 lbs]
Maximum Total Applied Load + Payload (F+W)	111 N [25 lbs]	178 N [40 lbs]	311 N [70 lbs]
Total Maximum Moment about any Axis (M)	8.4 Nm [75 in-lbs]	16.9 Nm [150 in-lbs]	33.9 Nm [300 in-lbs]

Shock Absorbers and Flow Controls are recommended for all applications

Internal Air Cylinder Linear Base Slides | Dimensions and Technical Specifications

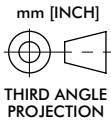
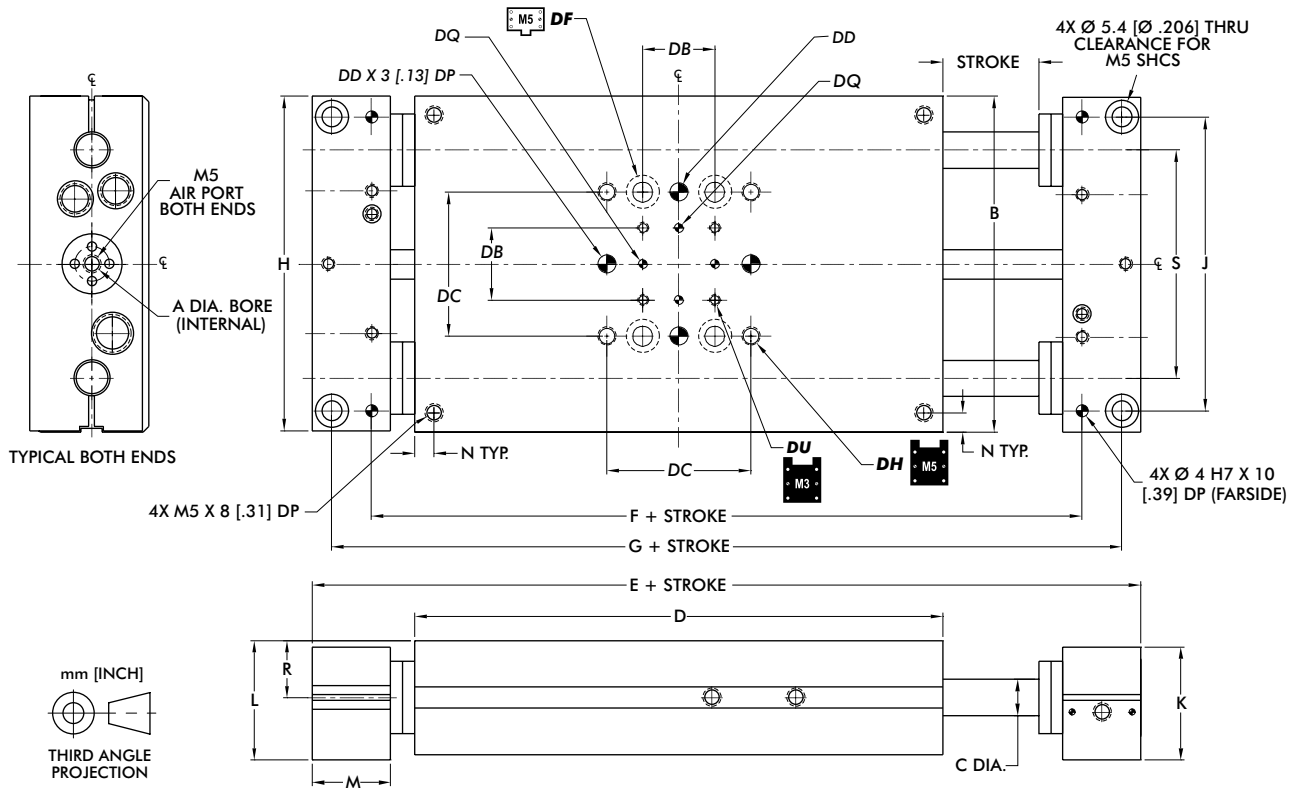

DIRECTCONNECT™ Mounting Pattern Dimensions (all sizes)

DB	DC	DD	DF	DH	DQ	DU
19.1 [0.750]	38.1 [1.500]	5mm H7 X 6 DP	CLEARANCE FOR M5	M5 X 8.5DP	3H7 X 2 DP	M3 X 6 DP

Model	Bore Ø	Body Size	Shaft Ø	Basic Unit Dimensions											
				A	B	C	D	E	F	G	H	J	K	L	M
DLB-10M	19 [0.75]	88.9 [3.50]	9.5 [0.375]	139.7 [5.50]	193.8 [7.63]	162.50 [6.3975]	183.6 [7.228]	88.5 [3.485]	77.72 [3.0600]	29.9 [1.178]	31.6 [1.245]		N/A	15.09 [0.594]	60.33 [2.375]
DLB-12M	25 [1.00]	101.6 [4.00]	12 [0.472]	165.1 [6.50]	219.2 [8.63]	187.90 [7.3975]	209.0 [8.228]	101.2 [3.985]	88.90 [3.5000]	41.0 [1.615]	42.1 [1.657]	20.7 [0.813]	9.5 [0.375]	20.65 [0.813]	69.85 [2.750]
DLB-16M		120.7 [4.75]	16 [0.630]	190.5 [7.50]	244.6 [9.63]	213.30 [8.3975]	234.4 [9.228]	120.3 [4.735]	107.95 [4.2500]						82.55 [3.250]

Dimensions in mm [in]

Loading Information

F=Externally applied force
W=Weight of payload
F+W=Total force
M=Maximum moment



	10	12	16
Maximum Payload (W) horizontal motion using Shock Absorbers	6.8 kg [15 lbs]	13.6 kg [30 lbs]	20.4 kg [45 lbs]
Maximum Payload (W) vertical motion using Shock Absorbers	3.1 kg [7 lbs]	6.8 kg [15 lbs]	9.9 kg [22 lbs]
Maximum Payload (W) horizontal motion using Urethane Bumpers	2.2 kg [5 lbs]	4.5 kg [10 lbs]	6.8 kg [15 lbs]
Maximum Total Applied Load + Payload (F+W)	111 N [25 lbs]	178 N [40 lbs]	311 N [70 lbs]
Total Maximum Moment about any Axis (M)	8.4 Nm [75 in-lbs]	16.9 Nm [150 in-lbs]	33.9 Nm [300 in-lbs]

Shock Absorbers and Flow Controls are recommended for all applications

DLB-20/25M-B

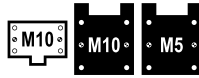

Internal Air Cylinder Linear Base Slides | Dimensions and Technical Specifications

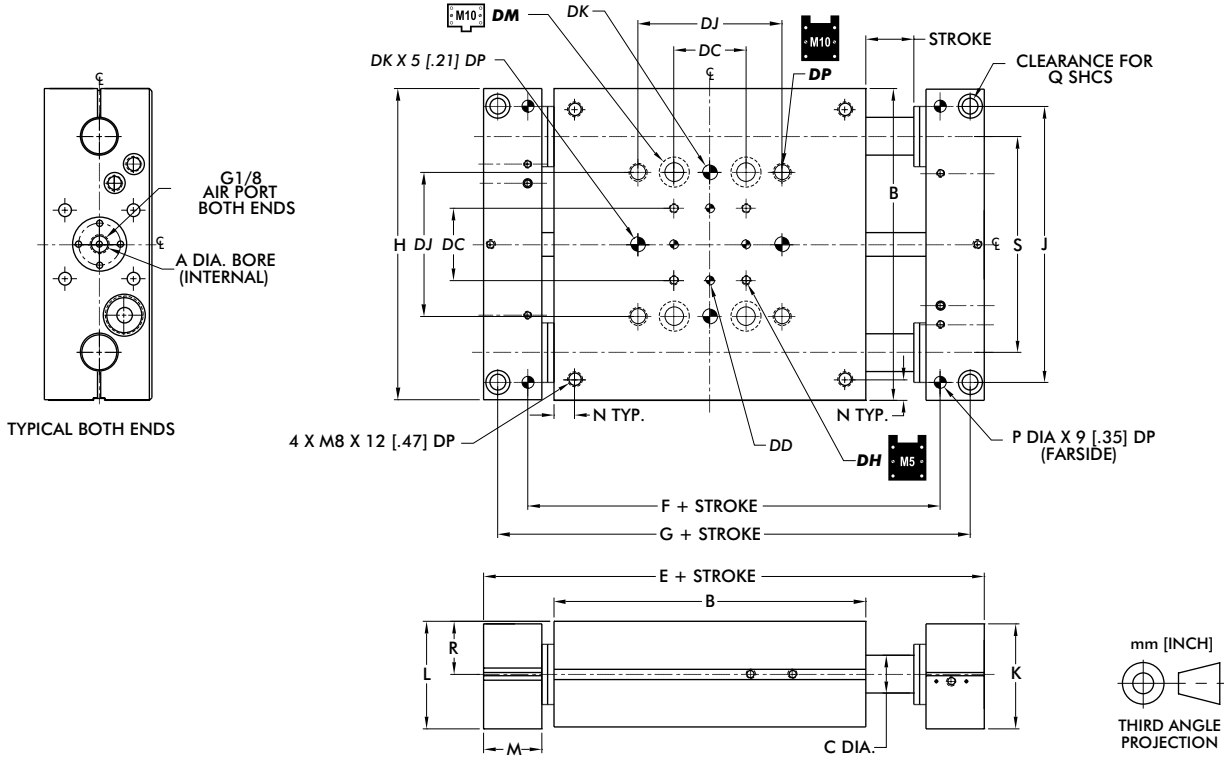

DIRECTCONNECT™ Mounting Pattern Dimensions (all sizes)

DC	DD	DH	DJ	DK	DM	DP
38.1 [1.500]	5 mm H7 X 6 DP	M5 X 8.5 DP	76.2 [3.000]	8 mm H7 X 9.4 DP	CLR & C'BORE FOR M10	M10 X 12 DP

Model	Bore Ø Body Size Shaft Ø			Basic Unit Dimensions												
	A	B	C	E	F	G	H	J	K	L	M	N	P	Q	R	S
DLB-20M	38	165.1 [6.50]	20 [0.787]	239.3 [9.42]	192.66 [7.5850]	224.4 [8.836]	164.6 [6.480]	146.05 [5.7500]	55.4	56.8	[1.210] 30.7	11.1	6.00 [0.2505]	M8	27.94	114.30 [4.500]
DLB-25M	[1.50]	190.5 [7.50]	25 [0.984]	275.3 [10.84]	221.79 [8.7320]	256.7 [10.108]	190.0 [7.480]	171.45 [6.7500]	[2.180]	[2.236]	[1.420] 36.1	[0.438]	8.00 [0.3130]	M10	[1.100]	133.35 [5.250]

Dimensions in mm [in]

Loading Information

- F**=Externally applied force
- W**=Weight of payload
- F+W**=Total force
- M**=Maximum moment

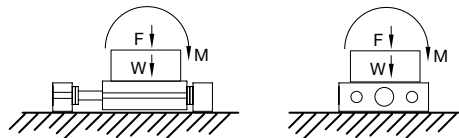

	20	25
Maximum Payload (W) horizontal motion using Shock Absorbers	27.2 kg [60 lbs]	45.3 kg [100 lbs]
Maximum Payload (W) vertical motion using Shock Absorbers	13.6 kg [30 lbs]	22.0 kg [50 lbs]
Maximum Payload (W) horizontal motion using Urethane Bumpers	9.1 kg [20 lbs]	11.3 kg [25 lbs]
Maximum Total Applied Load + Payload (F+W)	444 N [100 lbs]	667 N [150 lbs]
Total Maximum Moment about any Axis (M)	67.7 Nm [600 in-lbs]	135.5 Nm [1200 in-lbs]

Shock Absorbers and Flow Controls are recommended for all applications

Internal Air Cylinder Linear Base Slides | Dimensions and Technical Specifications

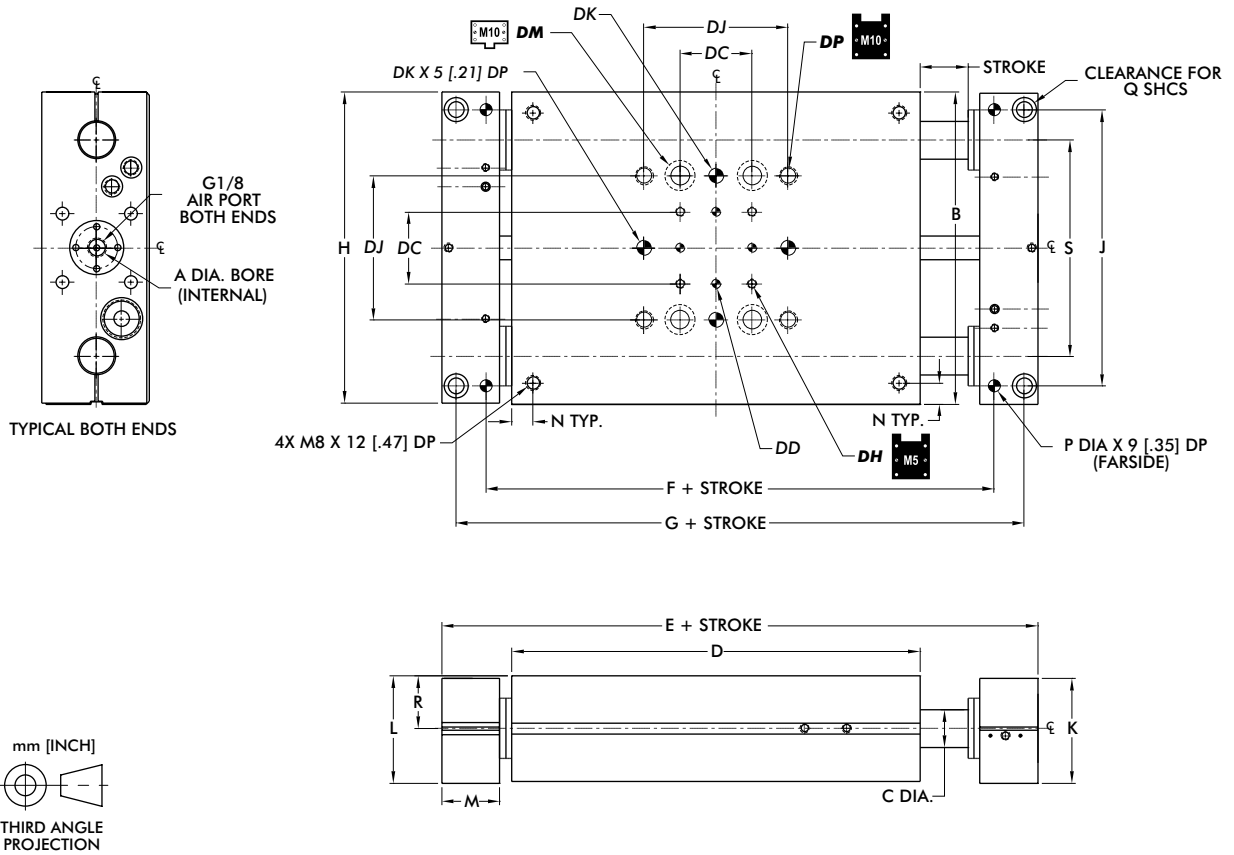

DIRECTCONNECT™ Mounting Pattern Dimensions (all sizes)

DC	DD	DH	DJ	DK	DM	DP
38.1 [1.500]	5 mm H7 X 6 DP	M5 X 8.5 DP	76.2 [3.000]	8 mm H7 X 9.4 DP	CLR & C'BORE FOR M10	M10 X 12 DP

Model	Bore Ø	Body Size	Shaft Ø	Basic Unit Dimensions												
				A	B	C	D	E	F	G	H	J	K	L	M	N
DLB-20M	38 [1.5]	165.1 [6.50]	20 [0.787]	215.9 [8.50]	290.1 [11.42]	243.46 [9.5850]	275.2 [10.836]	164.6 [6.480]	146.05 [5.7500]	55.4 [2.180]	56.8 [2.236]	30.7 [1.210]	6.00 [0.2505]	M8	27.94 [1.100]	114.30 [4.500]
DLB-25M		190.5 [7.50]	25 [0.984]	241.3 [9.50]	326.1 [12.84]	272.59 [10.7320]	307.5 [12.108]	190.0 [7.480]	171.45 [6.7500]	55.4 [2.180]		36.1 [1.420]	11.1 [0.438]			8.00 [0.3130]

Dimensions in mm [in]

Loading Information

- F**=Externally applied force
- W**=Weight of payload
- F+W**=Total force
- M**=Maximum moment

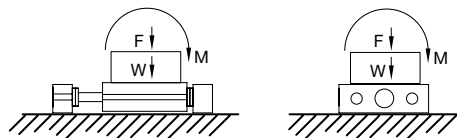

	20	25
Maximum Payload (W) horizontal motion using Shock Absorbers	27.2 kg [60 lbs]	45.3 kg [100 lbs]
Maximum Payload (W) vertical motion using Shock Absorbers	13.6 kg [30 lbs]	22.0 kg [50 lbs]
Maximum Payload (W) horizontal motion using Urethane Bumpers	9.1 kg [20 lbs]	11.3 kg [25 lbs]
Maximum Total Applied Load + Payload (F+W)	444 N [100 lbs]	667 N [150 lbs]
Total Maximum Moment about any Axis (M)	67.7 Nm [600 in-lbs]	[1200 in-lbs]

Shock Absorbers and Flow Controls are recommended for all applications

DLB SERIES - EXTERNAL AIR CYLINDER

External Air Cylinder Linear Base Slides | Features and Benefits | How To Order

Features:

- Bearing system for smooth operation
- Rugged design produces very reliable long life operation
- Replaceable air cylinder with adjustable cushion
- Non-powered Thrusters use customer supplied cylinders
- Urethane bumpers, hardened pads, oil wick
- Optional telescopic airlines transfers air to the cylinder
- DIRECTCONNECT™ mounting pattern
- Corrosion resistant shafting for corrosive environments
- Position sensing using inductive or magneto resistive sensors

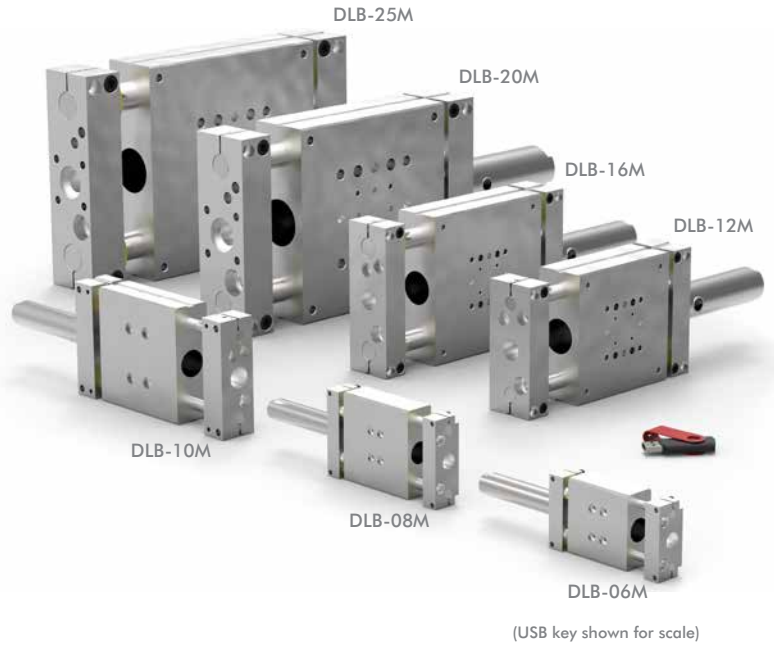

Applications:

- Machining and automation applications
- Harsh environment pick-and-place applications
- OEM machines
- Gantry systems

How To Order

Base Model DLB	Size	Styles Available	Style	Description
	06M	T, U	T	Replaceable cylinder w/o adjustable air cushions
	08M	T, U	A	Replaceable cylinder with adjustable air cushions
	10M	A, U	N	Repairable VDMA cylinder w/adjustable air cushions
	12M	A, U	R	Repairable locking VDMA cylinder w/adjustable air cushions
	16M	A, U	U	Non-powered unit*
	20M	N, R, U	*Without cylinder. Metric Units: Mount VDMA cylinder directly.	
25M	N, R, U			

Bearing	Description	Shafting	Description
B	Linear Ball Bearings*	"Blank"	Precision Hardened
C	Composite Bushings	S	Corrosion Resistant
	*Not available on -06 or -08		

Size	Style	Stroke [†] Metric (mm)
DLB-06M	T, U	10, 25, 40, 50, 75, 100, 125, 160
DLB-08M	T, U	10, 25, 40, 50, 75, 100, 125, 160, 175, 200
DLB-10M	A, U	25, 50, 80, 100, 125, 160, 200, 250, 300
DLB-12M	A, U	25, 50, 80, 100, 125, 160, 200, 250, 300, 320, 360, 400
DLB-16M	A, U	25, 50, 80, 100, 125, 160, 200, 250, 300, 320, 360, 400, 500
DLB-20M	N, R, U	25, 50, 80, 100, 125, 160, 200, 250, 300, 320, 360, 400, 500
DLB-25M	N, R, U	25, 50, 80, 100, 125, 160, 200, 250, 300, 320, 360, 400, 500

*Custom strokes available. Consult factory.

DLB SERIES - EXTERNAL AIR CYLINDER

External Air Cylinder Linear Base Slides | Accessories

Shock/Stop Accessories	Model Sizes	Style	Part Number	Qty/Unit
Shock Absorber	06, 08	All	SHOK-030	1-2
	10		SHOK-028	
	12, 16,		SHOK-010	
	20, 25		SHOK-029	
Adjustable Hard Stop	06, 08		DLT-0623	
	10, 12, 16, 20, 25		DLT-1023	

Sensor Accessories	Model Sizes	Style	Part Number	Qty/Unit
PNP Inductive Sensor with Quick Disconnect*	All Models	All	OISP-011	1-2
NPN Inductive Sensor with Quick Disconnect*			OISN-011	
PNP Magneto Resistive Sensor w/Qk Disconnect*	06, 08, 10, 12, 16	T, A	OHSP-005	
NPN Magneto Resistive Sensor w/Quick Disconnect*			OHSN-005	
PNP Magneto Resistive Sensor w/Qk Disconnect*	20, 25	N, R	OHSP-020	
Quick Disconnect 2 Meter Cable Length*	All Models	All	CABL-010	
Quick Disconnect 5 Meter Cable Length*			CABL-013	
Cable Extension Cord 1M Length*	All Models	All	CABL-015	
Cable Extension Cord 2M Length*			CABL-016	

Pneumatic Accessories	Model Sizes	Style	Part Number	Qty/Unit
G1/8 Telescopic Airlines (up to 160mm)	10, 12, 16	All	OTAL-045	1-4
G1/8 Telescopic Airlines (up to 300mm)	10, 12, 16		OTAL-046	
G1/8 Telescopic Airlines (up to 450mm)	10, 12, 16, 20, 25		OTAL-047	
G1/8 Telescopic Airlines (up to 600mm)	20M, 25M		OTAL-048	
G1/8 Adjustable Flow Control	10, 12, 16, 20, 25		VLVF-005	1-2
G1/8 Male to 1/8 NPT Adapter	20, 25	PLFT-025		

*Sensor and cable sold separately.

See page GR-LIN-35 for Accessory Mounting Technical Data.

DLB SERIES - EXTERNAL AIR CYLINDER

External Air Cylinder Linear Base Slides | Technical Specifications

Specifications	Units	06-T, U	08-T, U	10-A, U	12-A, U
Max. Air Pressure	bar [psi]	7 [100]			
Thrust Force @ 5.5 bar [80psi]	N [lbs]	89 [20]		145 [31]	289 [65]
Weight (basic unit)	kg [lb]	0.15 [0.34]	0.31 [0.69]	0.90 [1.98]	1.66 [3.73]
Additional Weight per Stroke	g/mm [lbs/in]	0.88 [0.05]	1.23 [0.07]	1.4 [0.09]	2.9 [0.16]
Cylinder Bore Ø	mm [in]	16 [0.563]		20 [0.75]	25 [1.00]
Shaft Ø	mm [in]	6 [0.236]	8 [0.315]	9.5 [0.375]	12 [0.472]
Maximum Moment Load	N-m [in-lbs]	1.7 [15]	3.4 [30]	8.4 [75]	16.9 [150]

Specifications	Units	16-A, U	20-A, N, R, U	25-A, N, R, U
Max. Air Pressure	bar [psi]	7 [100]		
Thrust Force @ 5.5 bar [80psi]	N [lbs]	289 [65]	443 [100]	443 [100]
Weight (basic unit)	kg [lb]	2.3 [5.03]	5.9 [12.9]	8.3 [18.0]
Additional Weight per Stroke	g/mm [lbs/in]	4.2 [0.23]	9.5 [0.53]	12.1 [0.68]
Cylinder Bore Ø	mm [in]	25 [1.00]	32 [1.25]	32 [1.25]
Shaft Ø	mm [in]	16 [0.630]	20 [0.787]	25 [0.984]
Maximum Moment Load	N-m [in-lbs]	33.9 [300]	67.8 [600]	135 [1200]
Min. Air Pressure to Release Cylinder Lock -R	bar [psi]		4 [60]	4 [60]
Holding Force of Locking Mechanism -R	N [lbs]		550 [123]	550 [123]

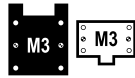

External Air Cylinder Linear Base Slides | Dimensions and Technical Specifications

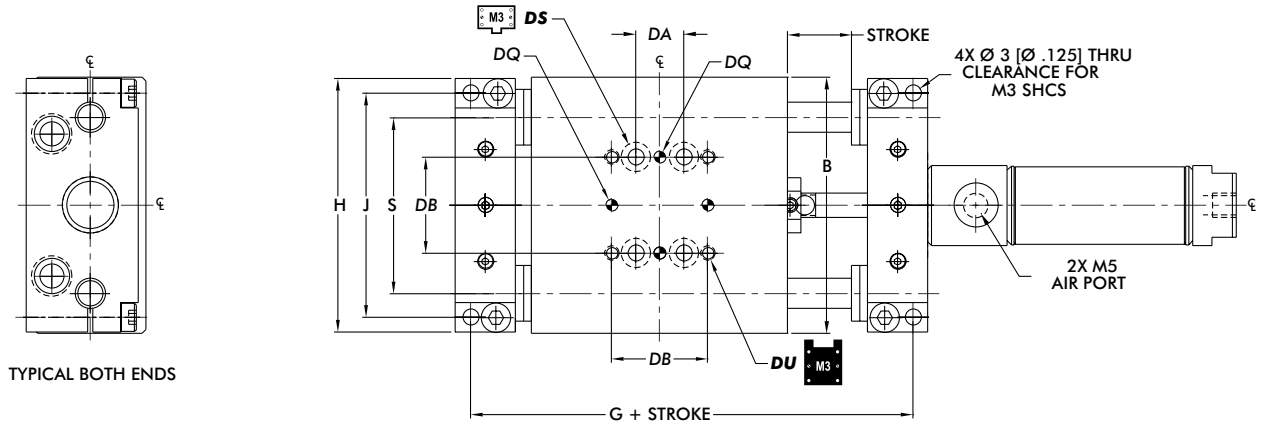

TYPICAL BOTH ENDS

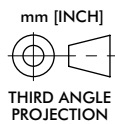

THIRD ANGLE PROJECTION

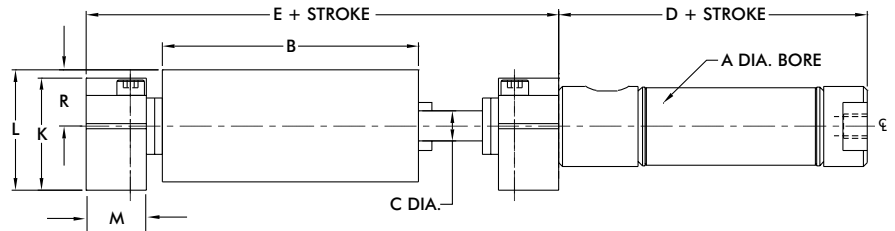

DIRECTCONNECT™ Mounting Pattern Dimensions (all sizes)

DA	DB	DQ	DS	DU
9.5 [0.375]	19.1 [0.750]	3H7 X 2 DP	CLR & C'BORE FOR M3	M3 x 6 DP

Model	Bore Ø	Body Size		Shaft Ø	Basic Unit Dimensions								
		A	B		C	D	E	G	H	J	K	L	M
DLB-06M	16 [0.563]	50.8 [2.00]	6.0 [0.236]	48.4 [1.91]	81.0 [3.19]	75.1 [2.956]	50.3 [1.980]	44.4 [1.750]	22.2 [0.875]	23.7 [0.936]	11.9 [0.470]	11.13 [0.438]	34.93 [1.375]
DLB-08M		63.5 [2.50]	8.0 [0.315]		93.7 [3.69]	87.8 [3.456]	62.7 [2.470]	57.1 [2.250]					44.45 [1.750]

Dimensions in mm [in]

Loading Information

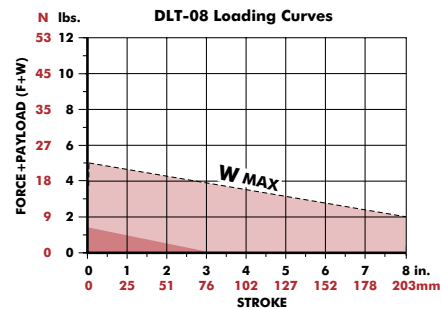
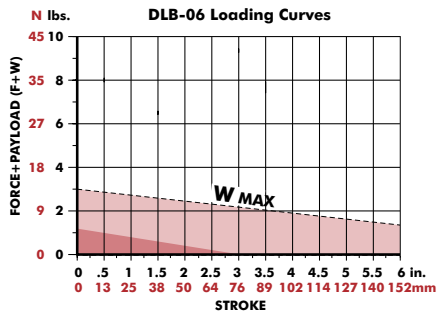

Shock Absorbers and Flow Controls are recommended for all applications

(W) in this range use Single Shock in both directions (W) in this range use Bumpers or Cushioned Cylinder

F=Externally applied force
W=Weight of payload
F+W=Total force

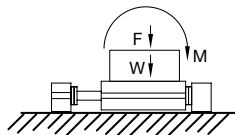

Shaded shock absorption ranges of horizontal payload (W) @ 80psi, flow controls fully open. For vertical applications do not exceed 1/2 of the recommended payload due to the additional acceleration effect of gravity.

DLB-10/12/16M-A, U

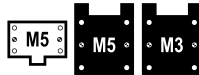

External Air Cylinder Linear Base Slides | Dimensions and Technical Specifications

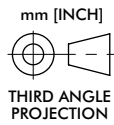
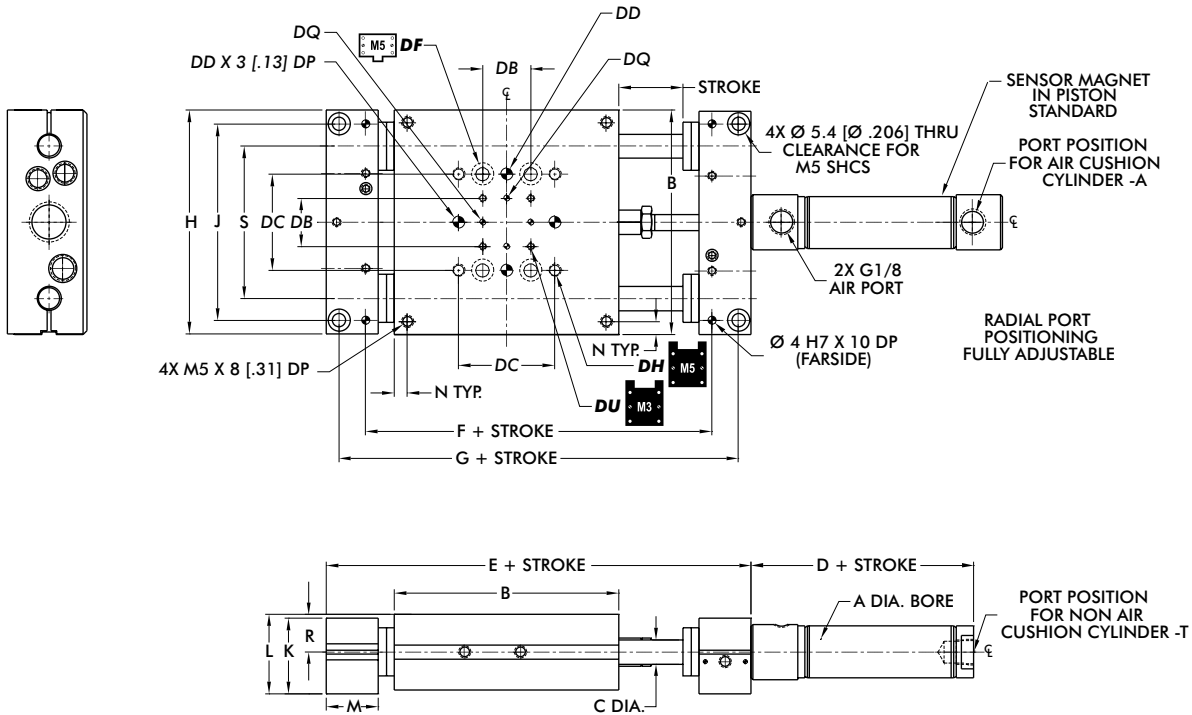

DIRECTCONNECT™ Mounting Pattern Dimensions (all sizes)						
DB	DC	DD	DF	DH	DQ	DU
19.1 [0.750]	38.1 [1.500]	5mm H7 X 6 DP	CLEARANCE FOR M5	M5 X 8.5DP	3H7 X 2 DP	M3 X 6 DP

Model	Bore Ø	Body Size	Shaft Ø	Basic Unit Dimensions											
				A	B	C	D	E	F	G	H	J	K	L	M
DLB-10M	20 [0.75]	88.9 [3.50]	9.5 [0.375]	88.0 [2.91]	149.4 [5.63]	118.05 [4.3975]	139.1 [5.228]	88.5 [3.485]	77.7 [3.060]	29.9 [1.178]	31.6 [1.245]		N/A	15.09 [0.594]	60.33 [2.375]
DLB-12M	25 [1.00]	101.6 [4.00]	12 [0.472]	91.5 [2.88]	162.1 [6.13]	130.75 [4.8975]	151.8 [5.728]	101.2 [3.985]	88.9 [3.500]	41.0 [1.615]	42.1 [1.657]	20.7 [0.813]	9.5 [0.375]	20.65 [0.813]	69.85 [2.750]
DLB-16M		120.7 [4.75]	16 [0.630]		181.1 [6.88]	149.80 [5.6475]	170.9 [6.478]	120.3 [4.735]	107.9 [4.250]						82.55 [3.250]

Dimensions in mm [in]

Loading Information

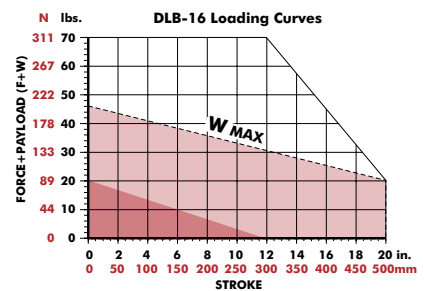
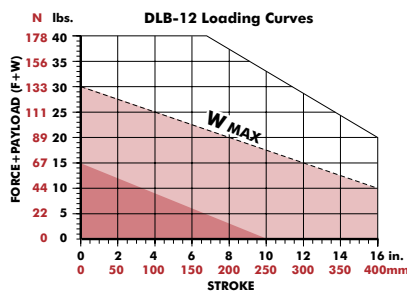
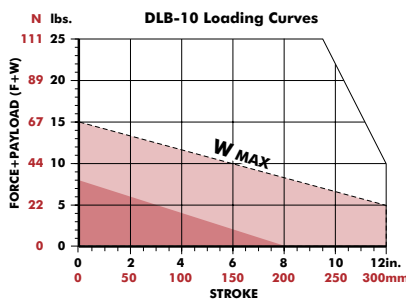

Shock Absorbers and Flow Controls are recommended for all applications

F=Externally applied force
W=Weight of payload
F+W=Total force

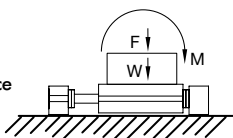

(W) in this range use Single Shock in both directions

(W) in this range use Bumpers or Cushioned Cylinder

Shaded shock absorption ranges of horizontal payload (W) @ 80psi, flow controls fully open. For vertical applications do not exceed 1/2 of the recommended payload due to the additional acceleration effect of gravity.

External Air Cylinder Linear Base Slides | Dimensions and Technical Specifications

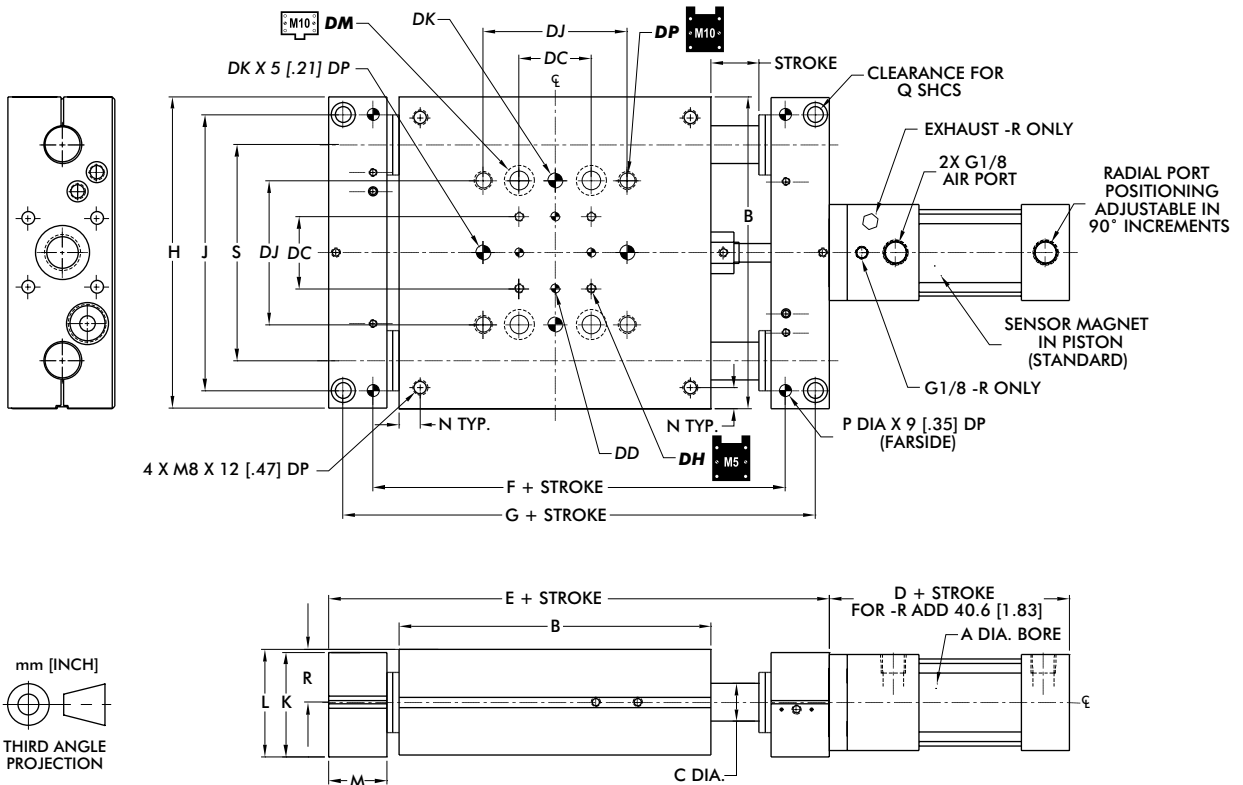

DIRECTCONNECT™ Mounting Pattern Dimensions (all sizes)						
DC	DD	DH	DJ	DK	DM	DP
38.1 [1.500]	5 mm H7 X 6 DP	M5 X 8.5 DP	76.2 [3.000]	8 mm H7 X 9.4 DP	CLR & C'BORE FOR M10	M10 X 12 DP

Model	Bore Ø Body Ø Shaft Ø			Basic Unit Dimensions													
	A	B	C	D	E	F	G	H	J	K	L	M	N	P	Q	R	S
DLB-20M	32 [1.25]	165.1 [6.50]	20 [0.787]	98.0 [3.63]	239.3 [9.42]	192.66 [7.5850]	224.4 [8.836]	164.6 [6.480]	146.05 [5.7500]	55.4 [2.180]	56.8 [2.236]	30.7 [1.210]	11.1 [0.438]	6.00 [0.2505]	M8	27.94 [1.100]	114.30 [4.500]
DLB-25M		190.5 [7.50]	25 [0.984]		275.3 [10.84]	221.79 [8.7320]	256.7 [10.108]	190.0 [7.480]	171.45 [6.7500]			36.1 [1.420]		8.00 [0.3130]	M10		113.35 [5.250]

Dimensions in mm [in]

Loading Information

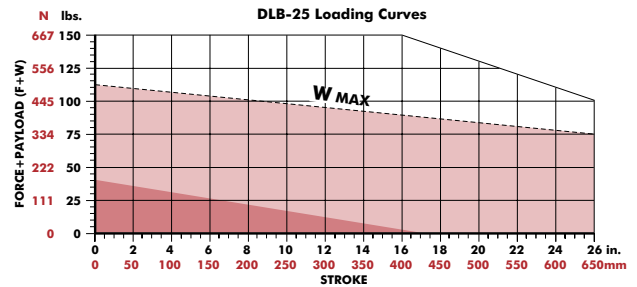
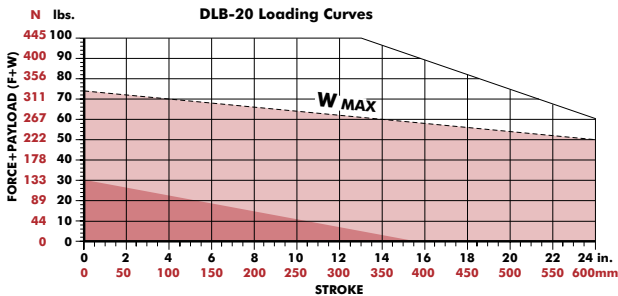

Shock Absorbers and Flow Controls are recommended for all applications

F=Externally applied force
W=Weight of payload
F+W=Total force

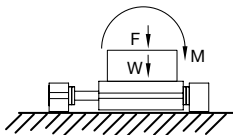

(W) in this range use **Single Shock** in both directions

(W) in this range use **Bumpers or Cushioned Cylinder**

Shaded shock absorption ranges of horizontal payload (W) @ 80psi, flow controls fully open. For vertical applications do not exceed 1/2 of the recommended payload due to the additional acceleration effect of gravity.

DLT SERIES - INTERNAL AIR CYLINDER

Internal Air Cylinder Linear Thruster Slides | Features and Benefits | How To Order

Features:

- 3 Models: **-B** block style, **-E** short body & **-L** long body
- Bearing system for smooth operation
- Rugged design produces very reliable long life operation
- Internal air cylinder for space-limited applications
- Urethane bumpers, hardened pads, oil wick
- Optional telescopic airlines transfers air to tooling
- DIRECTCONNECT™ mounting pattern
- Corrosion resistant shafting for corrosive environments
- Position sensing using inductive or magneto resistive sensors
- Viton® seals for high temperature applications

Applications:

- Machining, harsh environment, pick-and-place automation applications
- Lift table applications

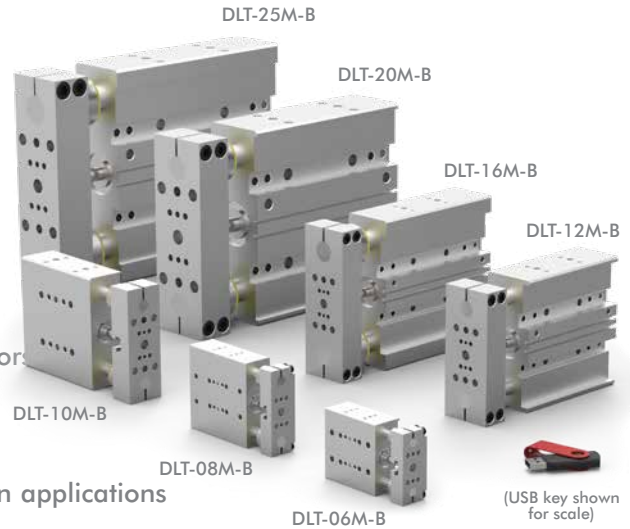

How To Order

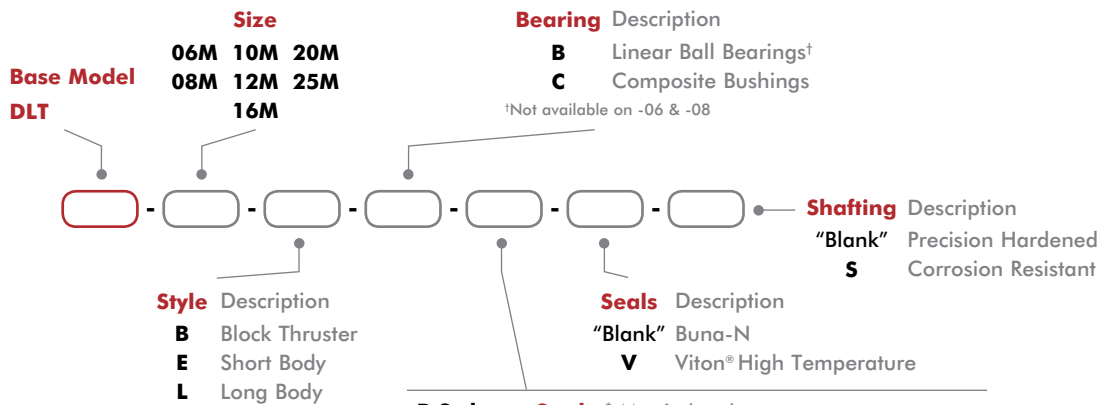

-B Style	Stroke* Metric (mm)
DLT-06M-B	6, 12, 25, 30
DLT-08M-B	6, 12, 25, 30, 40, 44
DLT-10M-B	12, 25, 40, 50
DLT-12M-B	12, 25, 40, 50
DLT-16M-B	12, 25, 40, 50, 65, 75
DLT-20M-B	12, 25, 40, 50, 65, 75, 85, 100
DLT-25M-B	12, 25, 40, 50, 65, 75, 85, 100, 115, 125

-E Style	Stroke* Metric (mm)
DLT-06M-E	6, 12, 25, 30
DLT-08M-E	6, 12, 25, 40, 44
DLT-10M-E	25, 50
DLT-12M-E	25, 50
DLT-16M-E	25, 50, 75
DLT-20M-E	25, 50, 75, 100
DLT-25M-E	25, 50, 75, 100, 125

-L Style	Stroke* Metric (mm)
DLT-06M-L	12, 25, 40, 50, 65, 75
DLT-08M-L	12, 25, 40, 50, 65, 75, 85
DLT-10M-L	25, 50, 80, 100
DLT-12M-L	25, 50, 80, 100, 125
DLT-16M-L	25, 50, 80, 100, 125, 150
DLT-20M-L	25, 50, 75, 100, 125, 160
DLT-25M-L	25, 50, 75, 100, 125, 160, 175

*Custom strokes available. Consult factory.

DLT SERIES - INTERNAL AIR CYLINDER

Internal Air Cylinder Linear Thruster Slides | Accessories

Shock/Stop & Mounting Accessories	Model Numbers	Style	Part Number	Qty/Unit
Universal Mounting Kit (Stop/Shock)	06	All	OSAK-069	1-2 on -B 1-4 on -E, -L
	08		OSAK-070	
Universal Mounting Kit (Stop/Shock/Sensor)	10		OSAK-055	
	12		OSAK-057	
	16		OSAK-059	
	20		OSAK-061	
	25		OSAK-063	
Shock Absorber	06, 08		SHOK-030	
	10		SHOK-028	
	12, 16,		SHOK-010	
	20, 25	SHOK-029		
Adjustable Hard Stop	06, 08	DLT-0623		
	10, 12, 16, 20, 25	DLT-1023		
Urethane Bumper/Stop Collar Kit	06	E, L	OSAK-067	1
	08		OSAK-068	
	10		OSAK-065	
	12		OSAK-066	
	16		OSAK-060	
	20		OSAK-062	
	25		OSAK-064	
Base Flange Kit	See Datasheet	B	--	

Sensor Accessories	Model Numbers	Style	Part Number	Qty/Unit
Inductive Sensor Mounting Kit	06	All	OSMK-076	1 on -B 1-2 on -E, -L 1-2
	08		OSMK-077	
PNP Inductive Sensor with Quick Disconnect*	06, 08		OISP-014	
NPN Inductive Sensor with Quick Disconnect*	10, 12, 16, 20, 25		OISN-014	
PNP Inductive Sensor with Quick Disconnect*			OISP-011	
NPN Inductive Sensor with Quick Disconnect*			OISN-011	
PNP Magneto Resistive with Quick Disconnect*			All Models	
NPN Magneto Resistive with Quick Disconnect*	All Models		OHSN-017	
Quick Disconnect 2 Meter Cable Length*			CABL-010	
Quick Disconnect 5 Meter Cable Length*			CABL-013	

*Sensor and cable sold separately.

Pneumatic Accessories	Model Numbers	Style	Part Number	Qty/Unit
G1/8 Telescopic Airlines (up to 50mm)	10, 12, 16	B, E	OTAL-043	1-4
G1/8 Telescopic Airlines (up to 80mm)		B, E, L	OTAL-044	
G1/8 Telescopic Airlines (up to 100mm)	20, 25	B, E	OTAL-051	
G1/8 Telescopic Airlines (up to 125mm)			OTAL-052	
G1/8 Telescopic Airlines (up to 160mm)	10, 12, 16	L	OTAL-045	
G1/8 Telescopic Airlines (up to 300mm)	20, 25		OTAL-046	
M5 Adjustable Flow Control	06, 08, 10, 12, 16	All	VLVF-008	1-2
G1/8 Adjustable Flow Control	20, 25		VLVF-005	
Seal Kits	See Datasheets			1

See page GR-LIN-36 for Accessory Mounting Technical Data.

DLT SERIES - INTERNAL AIR CYLINDER

Internal Air Cylinder Linear Thruster Slides | Technical Specifications

Specifications	Units	06-B, E	06-L	08-B, E	08-L	10-B, E	10-L	12-B, E	12-L
Max. Air Pressure	bar [psi]	7 [100]							
Thrust Force @ 5.5 bar [80psi]	N [lbs]	89 [20]				155 [35]		275 [62]	
Weight -B (basic unit)	kg [lb]	0.15 [0.34]	--	0.30 [0.65]	--	0.82 [1.81]	--	1.31 [2.88]	--
Weight -E, L (basic unit)	kg [lb]		0.28 [0.61]		0.44 [0.96]	0.84 [1.87]	0.88 [1.95]	1.35 [2.98]	1.46 [3.21]
Cylinder Bore Ø	mm [in]	14.3 [0.563]				19 [0.75]		25 [1.0]	
Shaft Ø	mm [in]	6 [0.236]		8 [0.315]		9.5 [0.375]		12 [0.472]	
Max (M) Vertical Motion	Nm [in-lbs]	0.6 [5]		1.1 [10]		2.8 [25]		5.6 [50]	

Specifications	Units	16-B, E	16-L	20-B, E	20-L	25-B, E	25-L
Max. Air Pressure	bar [psi]	7 [100]					
Thrust Force @ 5.5 bar [80psi]	N [lbs]	275 [62]		622 [140]			
Weight -B (basic unit)	kg [lb]	1.99 [4.38]	--	5.1 [11.6]	--	7.2 [15.7]	--
Weight -E, L (basic unit)	kg [lb]	2.07 [4.56]	2.03 [4.81]	5.2 [11.6]	5.5 [12.0]	7.4 [16.4]	7.9 [17.4]
Cylinder Bore Ø	mm [in]	25 [1.0]		38 [1.5]			
Shaft Ø	mm [in]	16 [0.630]		20 [0.787]		25 [0.984]	
Max (M) Vertical Motion	Nm [in-lbs]	11.3 [100]		28.2 [250]		56.4 [500]	



Internal Air Cylinder Linear Thruster Slides | Dimensions and Technical Specifications

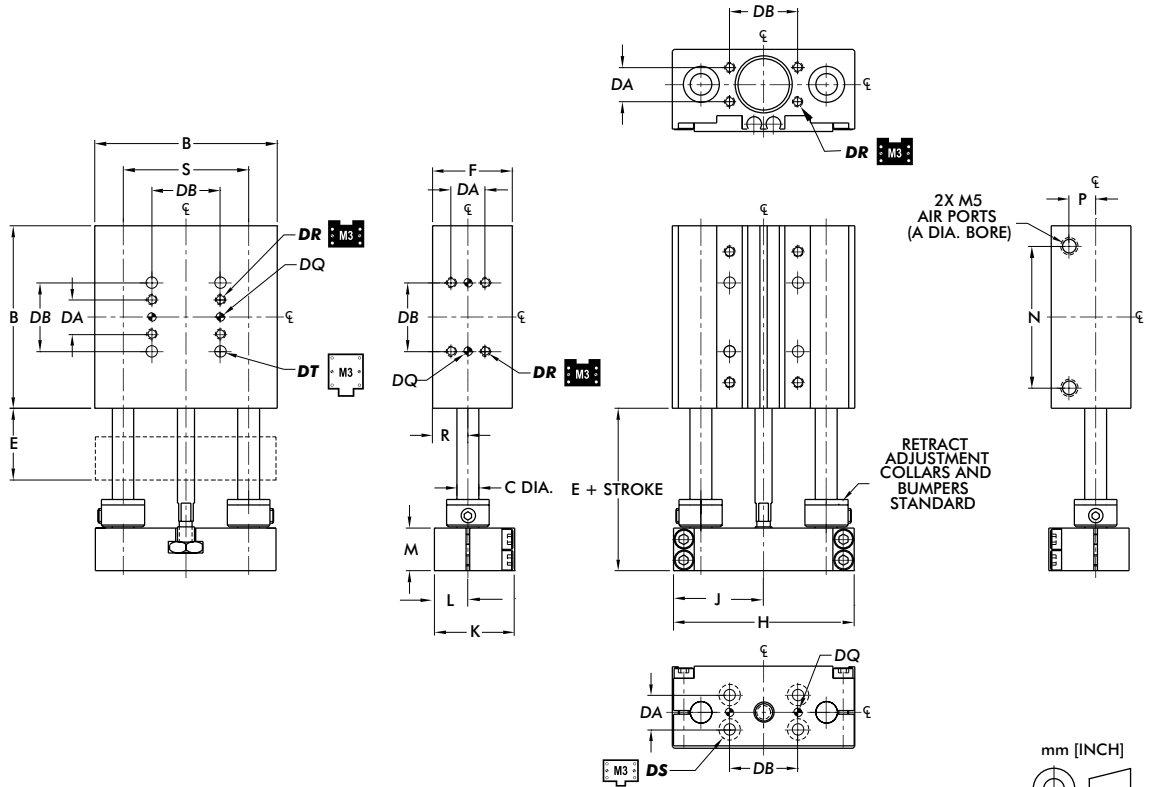

Pneumatic Accessories	Model	Part #	Qty/Unit
Cylinder Seal Kit (Buna-N)	ALL	SLKT-108	1
Cylinder Seal Kit (Viton®)		SLKT-108V	

DIRECTCONNECT™ Mounting Pattern Dimensions (all sizes)					
DA	DB	DQ	DR	DS	DT
9.5 [0.375]	19.1 [0.750]	3H7 X 2 DP	M3 x 6 DP	CLR & C'BORE FOR M3	CLR & C'BORE FOR M3

Model	Bore Ø			Body Size			Shaft Ø			Basic Unit Dimensions						
	A	B	C	E	F	H	J	K	L	M	N	P	R	S		
DLT-06M	14	50.8	6.0	19.9 [0.783]	22.4 [0.88]	50.3 [1.980]	25.1 [0.990]	22.2 [0.875]	9.3 [0.365]	11.9 [0.470]	39.4 [1.55]	7.4 [0.29]	9.9 [0.390]	34.93 [1.375]		
DLT-08M	[0.563]	63.5 [2.50]	8.0 [0.315]												52.1 [2.05]	44.45 [1.75]

Dimensions in mm [in]

Loading Information

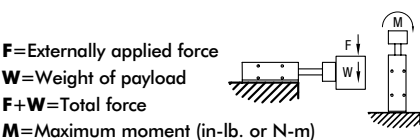
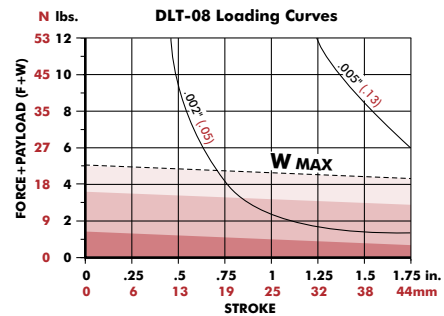
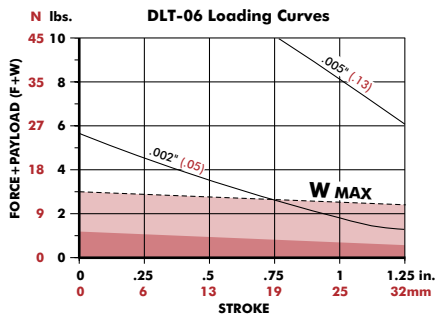

F=Externally applied force
W=Weight of payload
F+W=Total force
M=Maximum moment (in-lb. or N-m)

Shock Absorbers and Flow Controls are recommended for all applications

Use **Double Shocks** in both directions Use **Single Shock** in both directions Use **Bumpers or Cushioned Cylinder**

Shaded shock absorption ranges of horizontal payload (W) @ 80psi, flow controls fully open. For vertical applications do not exceed 1/2 of the recommended payload due to the additional acceleration effect of gravity.



Internal Air Cylinder Linear Thruster Slides | Dimensions and Technical Specifications

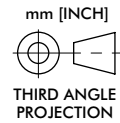
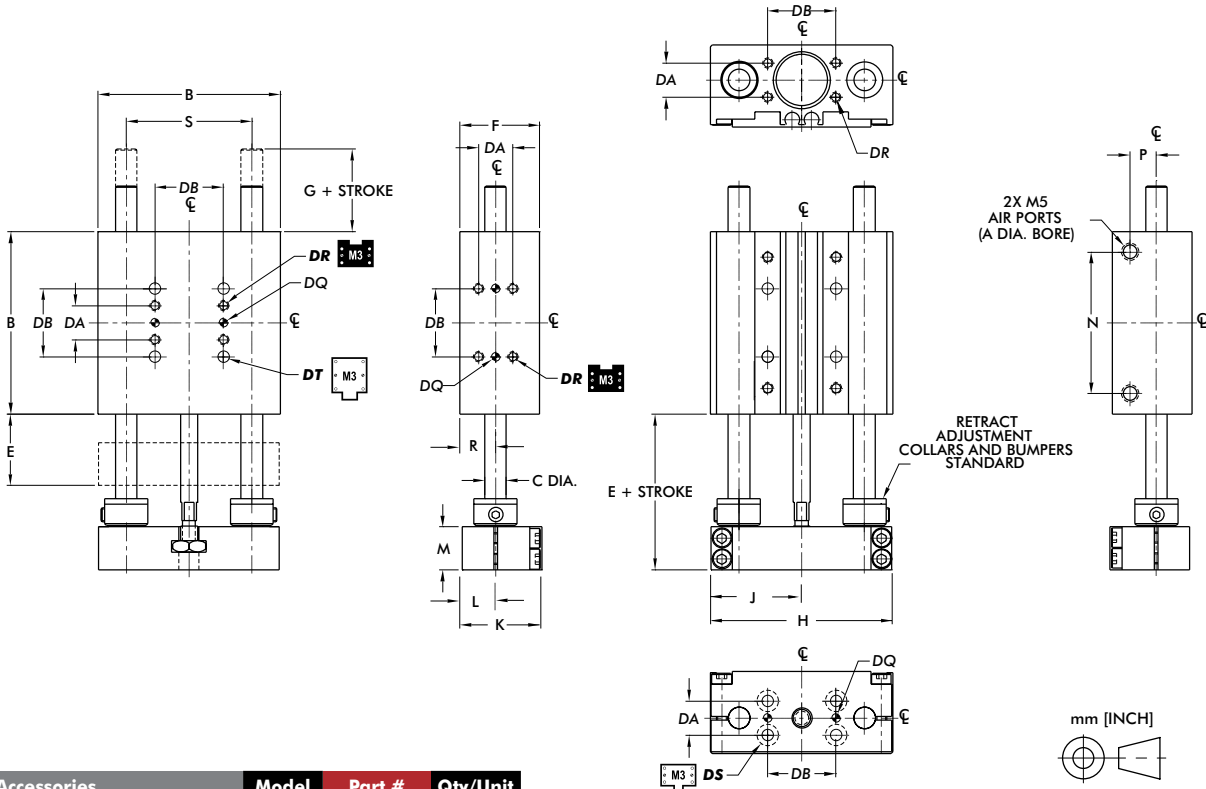

Pneumatic Accessories	Model	Part #	Qty/Unit
Cylinder Seal Kit (Buna-N)	ALL	SLKT-108	1
Cylinder Seal Kit (Viton®)		SLKT-108V	

DIRECTCONNECT™ Mounting Pattern Dimensions (all sizes)					
DA	DB	DQ	DR	DS	DT
9.5 [0.375]	19.1 [0.750]	3H7 X 2 DP	M3 x 6 DP	CLR & C'BORE FOR M3	CLR & C'BORE FOR M3

Model	Bore Ø Body Size Shaft Ø			Basic Unit Dimensions											
	A	B	C	E	F	G	H	J	K	L	M	N	P	R	S
DLT-06M	14 [0.563]	50.8 [2.00]	6.0 [0.236]	19.9 [0.783]	22.4 [0.88]	16.8 [0.66]	50.3 [1.980]	25.1 [0.990]	22.2 [0.875]	9.3 [0.365]	11.9 [0.470]	39.4 [1.55]	7.4 [0.29]	9.9 [0.390]	34.93 [1.375]
DLT-08M		63.5 [2.50]	8.0 [0.315]			10.4 [0.41]	62.7 [2.470]	31.0 [1.235]				52.1 [2.05]			44.45 [1.750]

Dimensions in mm [in]

Loading Information

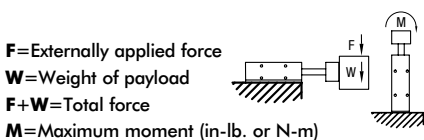
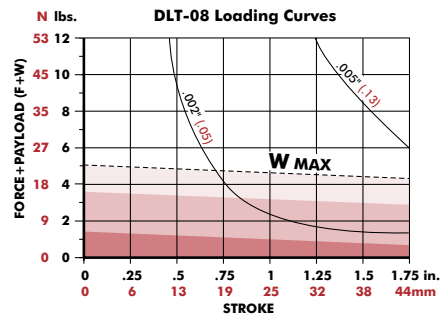
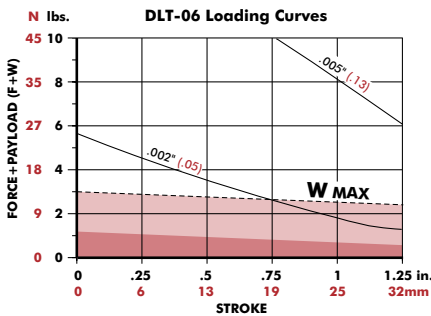

Shock Absorbers and Flow Controls are recommended for all applications

- Use **Double Shocks** in both directions
- Use **Single Shock** in both directions
- Use **Bumpers or Cushioned Cylinder**

Shaded shock absorption ranges of horizontal payload (W) @ 80psi, flow controls fully open. For vertical applications do not exceed 1/2 of the recommended payload due to the additional acceleration effect of gravity.



Internal Air Cylinder Linear Thruster Slides | Dimensions and Technical Specifications

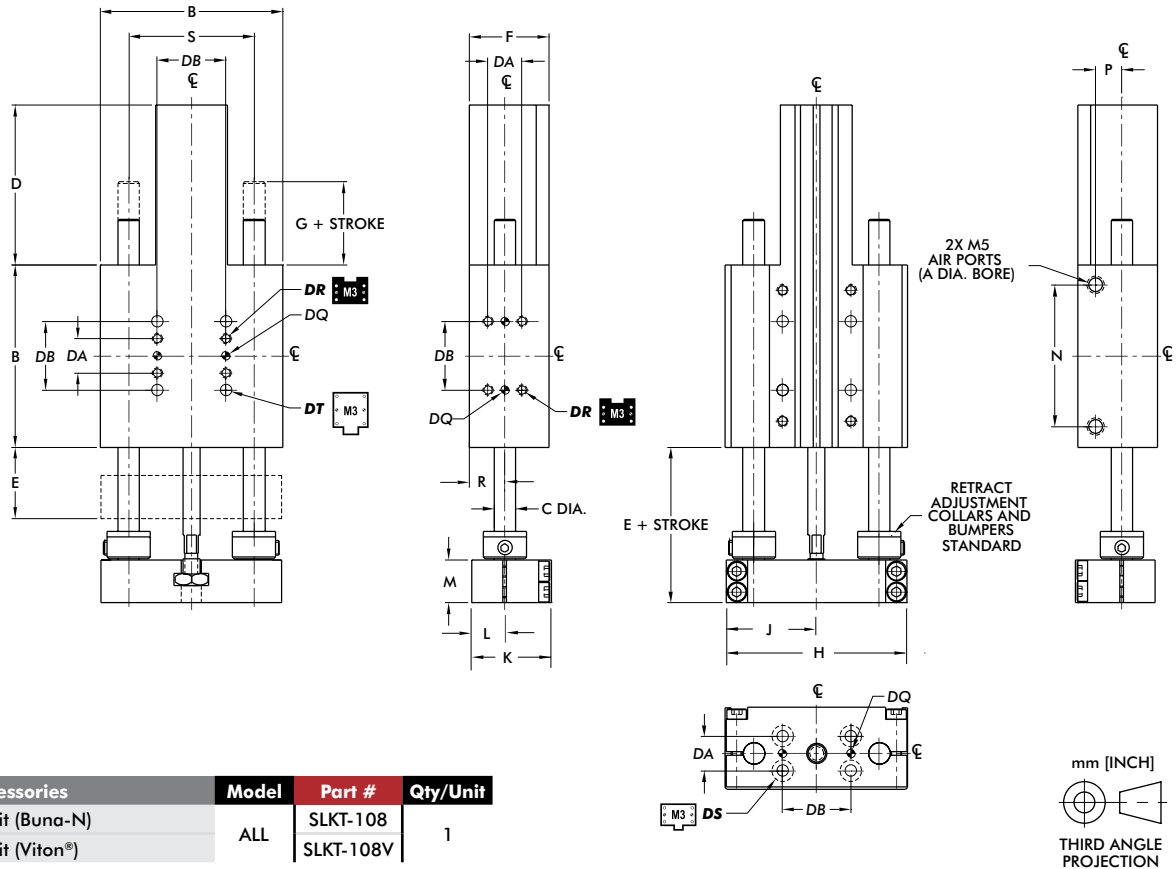

Pneumatic Accessories	Model	Part #	Qty/Unit
Cylinder Seal Kit (Buna-N)	ALL	SLKT-108	1
Cylinder Seal Kit (Viton®)		SLKT-108V	

DIRECTCONNECT™ Mounting Pattern Dimensions (all sizes)					
DA	DB	DQ	DR	DS	DT
9.5 [0.375]	19.1 [0.750]	3H7 X 2 DP	M3 x 6 DP	CLR & C'BORE FOR M3	CLR & C'BORE FOR M3

Model	Bore Ø Body Size Shaft Ø			Basic Unit Dimensions												
	A	B	C	D	E	F	G	H	J	K	L	M	N	P	R	S
DLT-06M	14 [0.563]	50.8 [2.00]	6.0 [0.236]	44.4 [1.75]	19.9 [0.783]	22.4 [0.88]	16.8 [0.66]	50.3 [1.980]	25.1 [0.990]	22.2 [0.875]	9.3 [0.365]	11.9 [0.470]	39.4 [1.55]	5.4 [0.21]	9.9 [0.390]	34.93 [1.375]
DLT-08M		63.5 [2.50]	8.0 [0.315]					10.4 [0.41]	62.7 [2.470]	31.0 [1.235]				52.1 [2.05]		

Dimensions in mm [in]

Loading Information

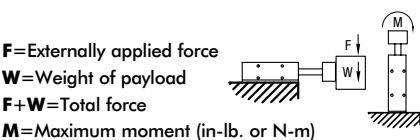
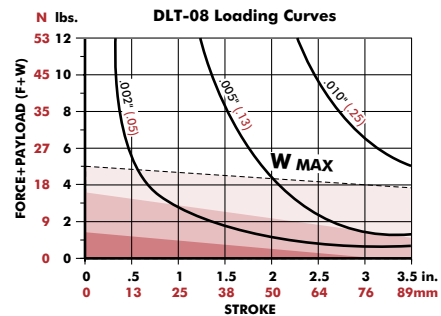
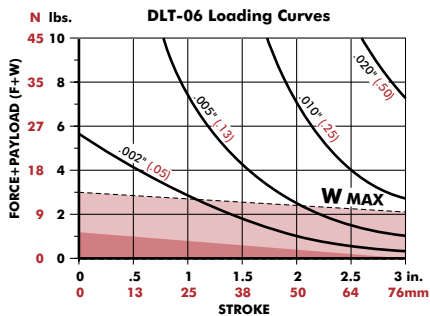

Shock Absorbers and Flow Controls are recommended for all applications

Use **Double Shocks** in both directions Use **Single Shock** in both directions Use **Bumpers or Cushioned Cylinder**

Shaded shock absorption ranges of horizontal payload (W) @ 80psi, flow controls fully open. For vertical applications do not exceed 1/2 of the recommended payload due to the additional acceleration effect of gravity.



Internal Air Cylinder Linear Thruster Slides | Dimensions and Technical Specifications

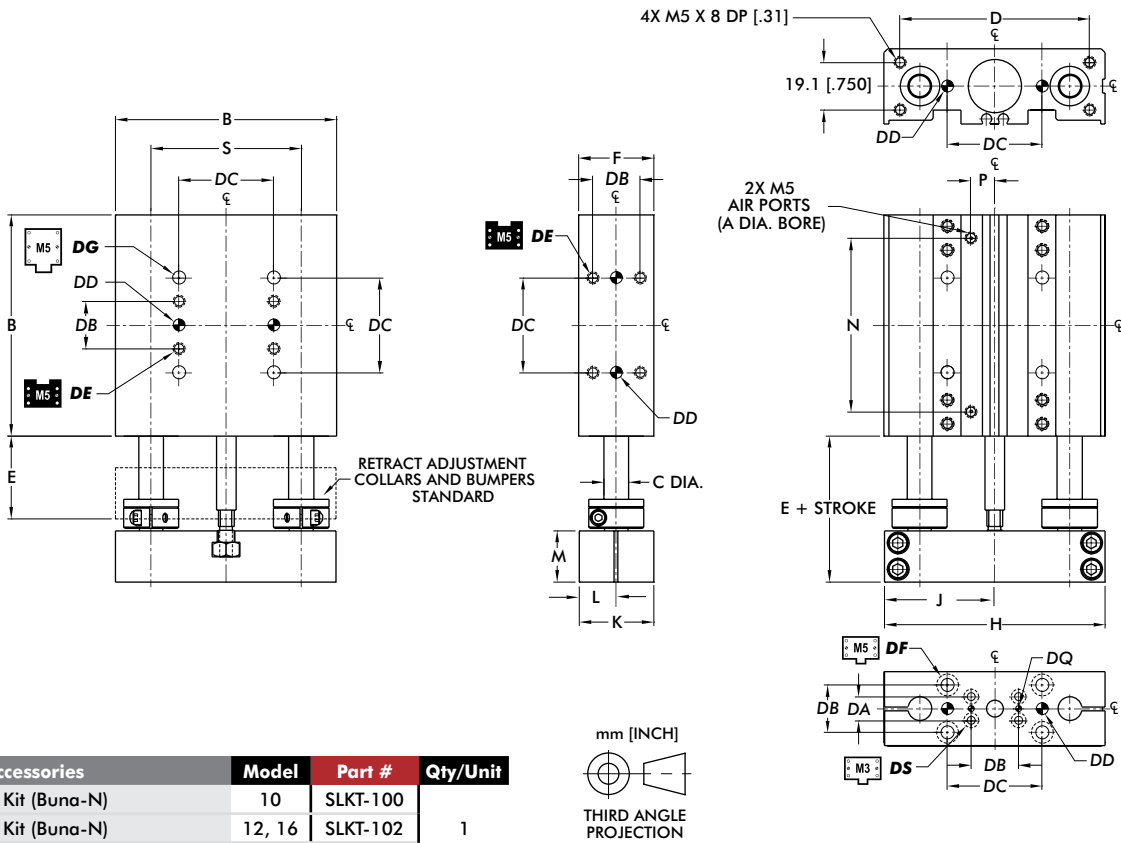

Pneumatic Accessories	Model	Part #	Qty/Unit
Cylinder Seal Kit (Buna-N)	10	SLKT-100	1
Cylinder Seal Kit (Buna-N)	12, 16	SLKT-102	
Cylinder Seal Kit (Viton®)	10	SLKT-100V	
Cylinder Seal Kit (Viton®)	12, 16	SLKT-102V	

DIRECTCONNECT™ Mounting Pattern Dimensions (all sizes)								
DA	DB	DC	DD	DE	DF	DG	DQ	DS
9.5 [0.375]	19.1 [0.750]	38.1 [1.500]	5mm H7 X 6 DP	M5 X 8.5 DP	CLEARANCE FOR M5		3H7 X 2 DP	CLR & C'BORE FOR M3

Model	Bore Ø			Body Size			Shaft Ø			Basic Unit Dimensions						
	A	B	C	D	E	F	H	J	K	L	M	N	P	S		
DLB-10M	19 [0.75]	88.9 [3.50]	9.5 [0.375]	76.2 [3.000]	33.4 [1.313]	30.2 [1.19]	88.6 [3.490]	44.2 [1.740]	29.9 [1.178]	14.8 [0.584]	20.7 [0.813]	69.7 [2.75]	9.4 [0.37]	60.33 [2.375]		
DLB-12M	25 [0.98]	101.6 [4.00]	12.0 [0.472]	92.1 [3.625]		41.4 [1.63]	101.2 [3.985]	50.4 [1.985]	41.0 [1.615]	20.4 [0.802]		83.3 [3.28]		69.85 [2.750]		
DLB-16M		120.7 [4.75]	16.0 [0.630]	111.1 [4.375]	34.9 [1.375]	120.3 [4.735]	59.9 [2.360]	102.4 [4.03]	82.55 [3.250]							

Dimensions in mm [in]

Loading Information

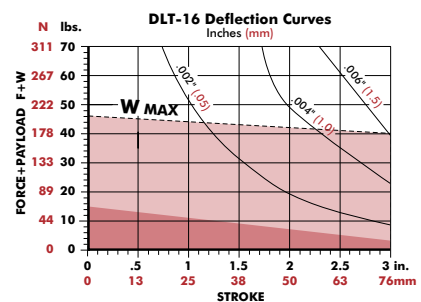
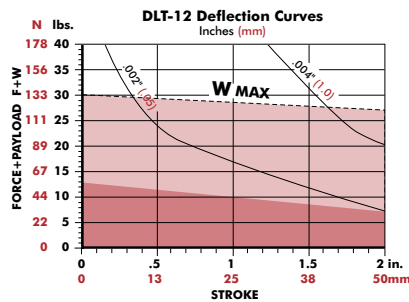
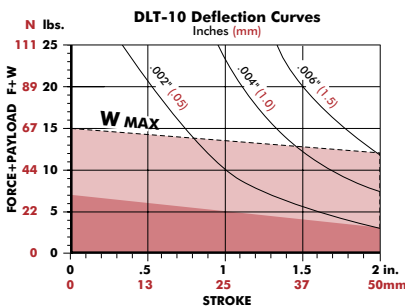

Shock Absorbers and Flow Controls are recommended for all applications

F=Externally applied force
W=Weight of payload
F+W=Total force

M=Maximum moment (in-lb. or N-m)

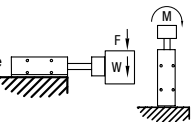

(W) in this range use **Single Shock** in retract directions

(W) in this range use **Bumpers or Cushioned Cylinder**

Shaded shock absorption ranges of horizontal payload (W) @ 80psi, flow controls fully open. For vertical applications do not exceed 1/2 of the recommended payload due to the additional acceleration effect of gravity.

Internal Air Cylinder Linear Thruster Slides | Dimensions and Technical Specifications

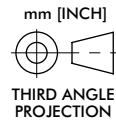
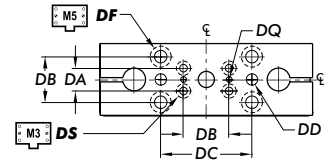
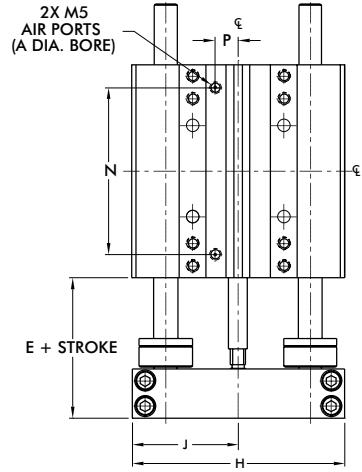
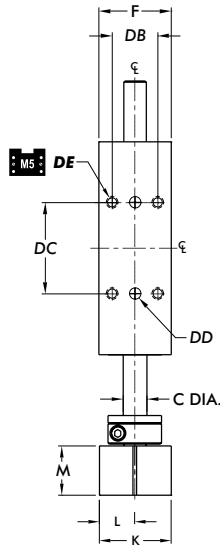
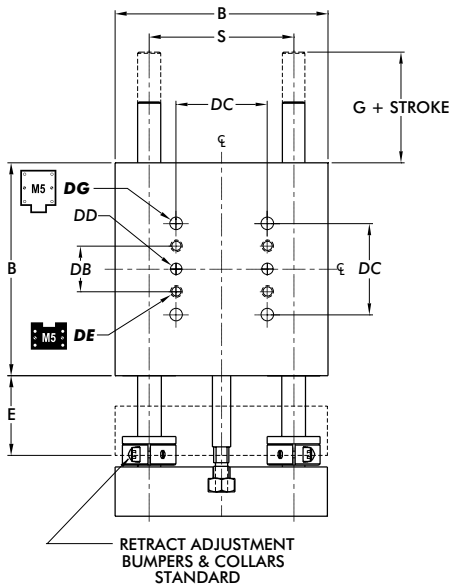

Pneumatic Accessories	Model	Part #	Qty/Unit
Cylinder Seal Kit (Buna-N)	10	SLKT-100	1
Cylinder Seal Kit (Buna-N)	12, 16	SLKT-102	
Cylinder Seal Kit (Viton®)	10	SLKT-100V	
Cylinder Seal Kit (Viton®)	12, 16	SLKT-102V	

DIRECTCONNECT™ Mounting Pattern Dimensions (all sizes)									
DA	DB	DC	DD	DE	DF	DG	DQ	DS	
9.5 [0.375]	19.1 [0.750]	38.1 [1.500]	5mm H7 X 6 DP	M5 X 8.5 DP	CLEARANCE FOR M5		3H7 X 2 DP	CLR & C'BORE FOR M3	

Model	Bore Ø Body Size Shaft Ø			Basic Unit Dimensions										
	A	B	C	E	F	G	H	J	K	L	M	N	P	S
DLB-10M	19 [3/4]	88.9 [3.50]	9.5 [0.375]	33.4 [1.313]	30.2 [1.19]	20.8 [0.82]	88.6 [3.490]	44.2 [1.740]	29.9 [1.178]	14.8 [0.584]		69.7 [2.75]		60.33 [2.375]
DLB-12M	25 [1]	101.6 [4.00]	12.0 [0.472]	34.9 [1.375]	41.4 [1.63]	19.3 [0.76]	101.2 [3.985]	50.4 [1.985]	41.0 [1.615]	20.4 [0.802]	20.7 [0.813]	83.3 [3.28]	9.4 [0.37]	69.85 [2.750]
DLB-16M		120.7 [4.75]	16.0 [0.630]		120.3 [4.735]	59.9 [2.360]	102.4 [4.03]	82.55 [3.250]						

Dimensions in mm [in]

Loading Information

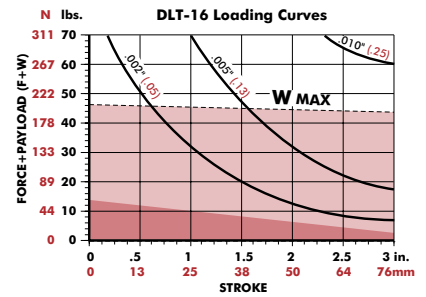
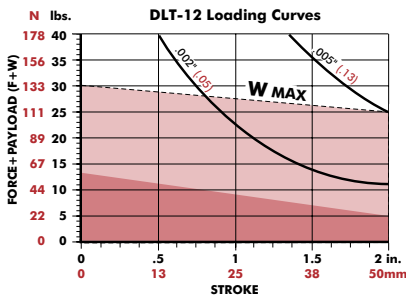
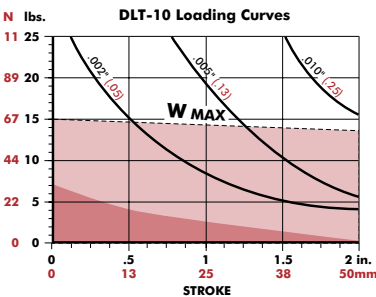

Shock Absorbers and Flow Controls are recommended for all applications

(W) in this range use **Single Shock** in retract directions

(W) in this range use **Bumpers or Cushioned Cylinder**

F=Externally applied force
W=Weight of payload
F+W=Total force
M=Maximum moment (in-lb. or N-m)

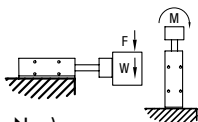

Shaded shock absorption ranges of horizontal payload (W) @ 80psi, flow controls fully open. For vertical applications do not exceed 1/2 of the recommended payload due to the additional acceleration effect of gravity.

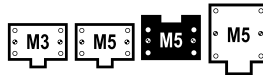

Internal Air Cylinder Linear Thruster Slides | Dimensions and Technical Specifications

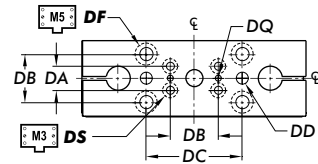
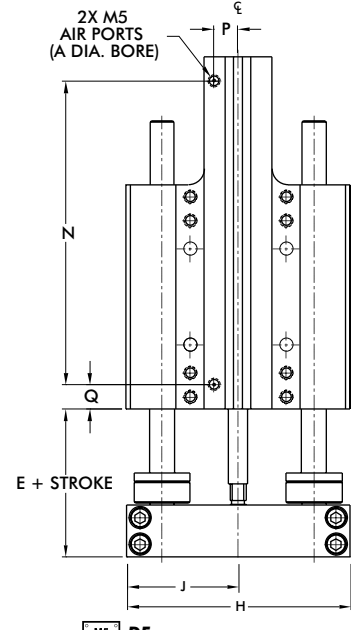
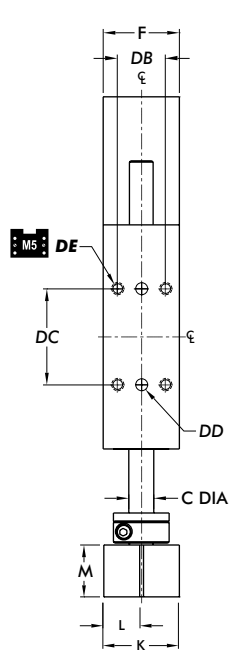
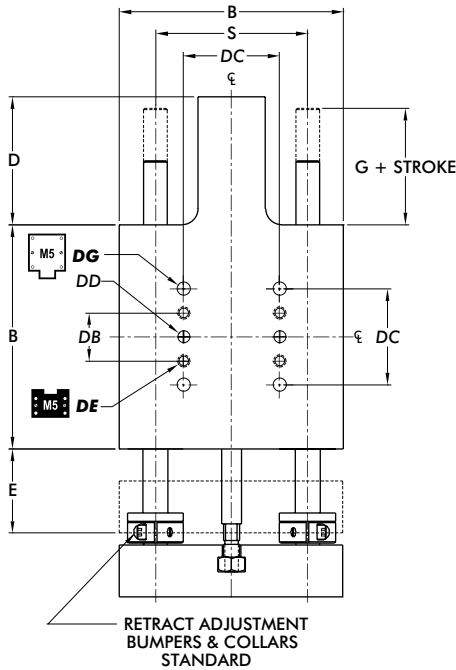

Pneumatic Accessories	Model	Part #	Qty/Unit
Cylinder Seal Kit (Buna-N)	10	SLKT-100	1
Cylinder Seal Kit (Buna-N)	12, 16	SLKT-102	
Cylinder Seal Kit (Viton®)	10	SLKT-100V	
Cylinder Seal Kit (Viton®)	12, 16	SLKT-102V	

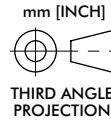

DIRECTCONNECT™ Mounting Pattern Dimensions (all sizes)									
DA	DB	DC	DD	DE	DF	DG	DQ	DS	
9.5 [0.375]	19.1 [0.750]	38.1 [1.500]	5mm H7 X 6 DP	M5 X 8.5 DP	CLEARANCE FOR M5		3H7 X 2 DP	CLR & C'BORE FOR M3	

Model	Bore Ø	Body Size	Shaft Ø	Basic Unit Dimensions												
				A	B	C	D	E	F	G	H	J	K	L	M	N
DLB-10M	19 [3/4]	88.9 [3.50]	9.5 [0.375]	50.8 [2.00]	33.4 [1.313]	30.2 [1.19]	20.8 [0.82]	88.6 [3.490]	44.2 [1.740]	29.9 [1.178]	14.8 [0.584]		120.7 [4.75]	9.6 [0.38]	9.6 [0.38]	60.33 [2.375]
DLB-12M	25 [1]	101.6 [4.00]	12.0 [0.472]	63.5 [2.50]		41.4 [1.63]		101.2 [3.985]	50.4 [1.985]			20.7 [0.813]	146.8 [5.78]	9.4 [0.37]	9.1 [0.36]	69.85 [2.750]
DLB-16M		120.7 [4.75]	16.0 [0.630]	69.9 [2.75]	34.9 [1.375]	19.3 [0.76]	120.3 [4.735]	59.9 [2.360]						172.2 [6.78]		

Dimensions in mm [in]

Loading Information

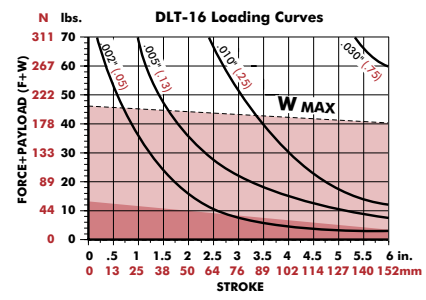
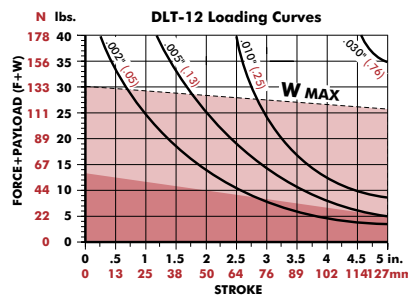
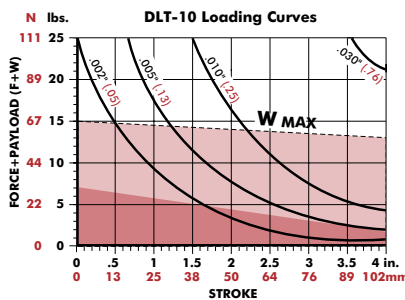

Shock Absorbers and Flow Controls are recommended for all applications

F=Externally applied force
W=Weight of payload
F+W=Total force

M=Maximum moment (in-lb. or N-m)

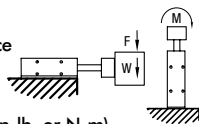

(W) in this range use **Single Shock** in retract directions

(W) in this range use **Bumpers or Cushioned Cylinder**

Shaded shock absorption ranges of horizontal payload (W) @ 80psi, flow controls fully open. For vertical applications do not exceed 1/2 of the recommended payload due to the additional acceleration effect of gravity.

Internal Air Cylinder Linear Thruster Slides | Dimensions and Technical Specifications

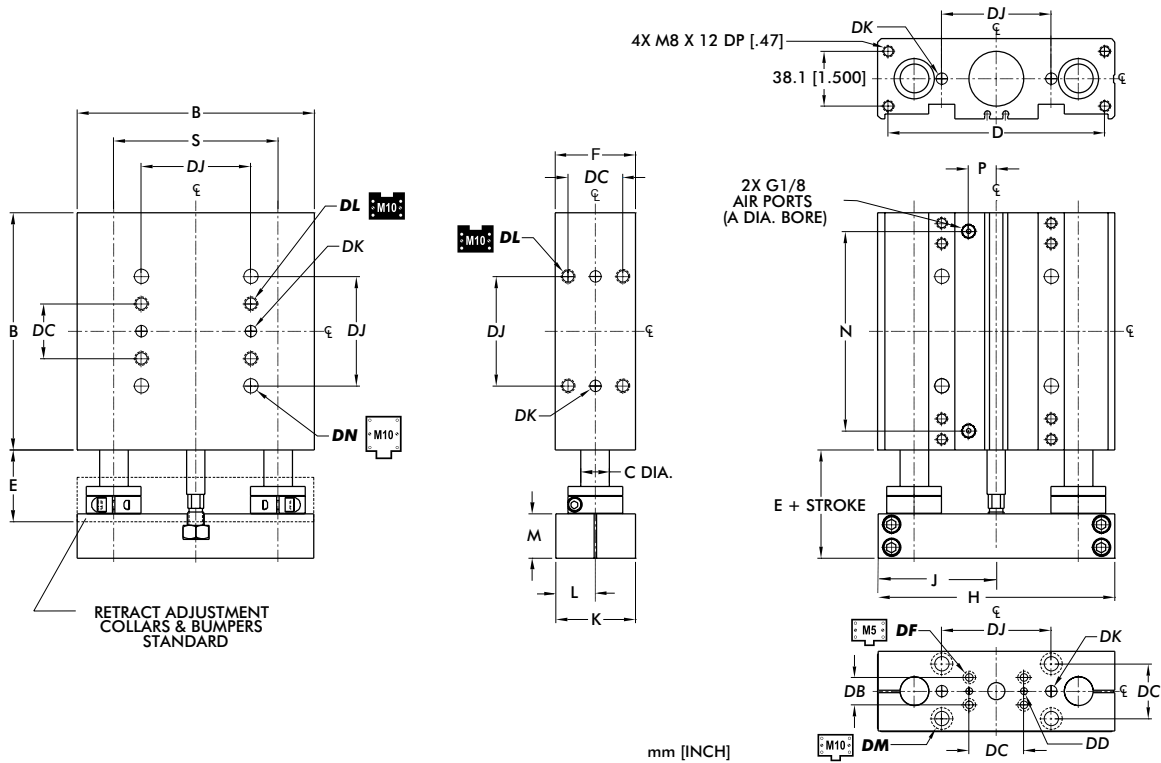

Pneumatic Accessories	Model	Part #	Qty/Unit
Cylinder Seal Kit (Buna-N)	20	SLKT-104	1
Cylinder Seal Kit (Viton®)	25	SLKT-104V	1

DIRECTCONNECT™ Mounting Pattern Dimensions (all sizes)									
DB	DC	DD	DF	DJ	DK	DL	DM	DN	
19.1 [0.750]	38.1 [1.500]	5mm H7 X 6 DP	CLEARANCE FOR M5	76.2 [3.000]	8mm H7 x 9.4 DP	M10 x 14.2 DP	CLR & C'BORE FOR M10		

Model	Bore Ø			Basic Unit Dimensions										
	A	B	C	D	E	F	H	J	K	L	M	N	P	S
DLB-20M	38	165.1 [6.50]	20 [0.787]	150.8 [5.938]	49.8 [1.960]	55.9 [2.20]	164.6 [6.480]	82.0 [3.230]	55.4 [2.180]	27.4 [1.080]	30.7 [1.210]	138.9 [5.47]	19.5 [0.77]	114.30 [4.500]
DLB-25M	38	190.5 [7.50]	25 [0.984]	176.2 [6.938]	55.1 [2.170]		190.0 [7.480]	94.7 [3.730]			36.1 [1.420]	164.3 [6.47]		133.35 [5.250]

Dimensions in mm [in]

Loading Information

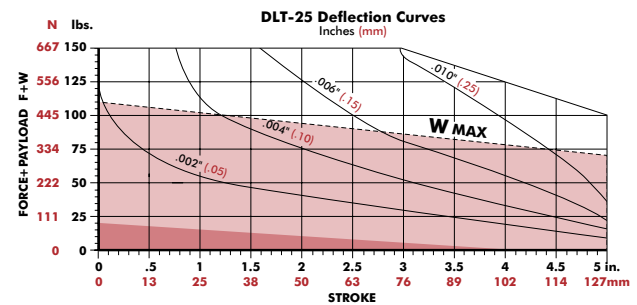
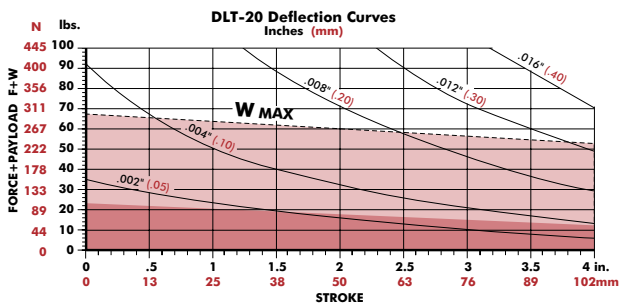

Shock Absorbers and Flow Controls are recommended for all applications

F=Externally applied force
 W=Weight of payload
 F+W=Total force
 M=Maximum moment (in-lb. or N-m)

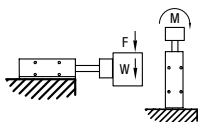

(W) in this range use Single Shock in retract directions (W) in this range use Bumpers or Cushioned Cylinder

Shaded shock absorption ranges of horizontal payload (W) @ 80psi, flow controls fully open. For vertical applications do not exceed 1/2 of the recommended payload due to the additional acceleration effect of gravity.

Internal Air Cylinder Linear Thruster Slides | Dimensions and Technical Specifications

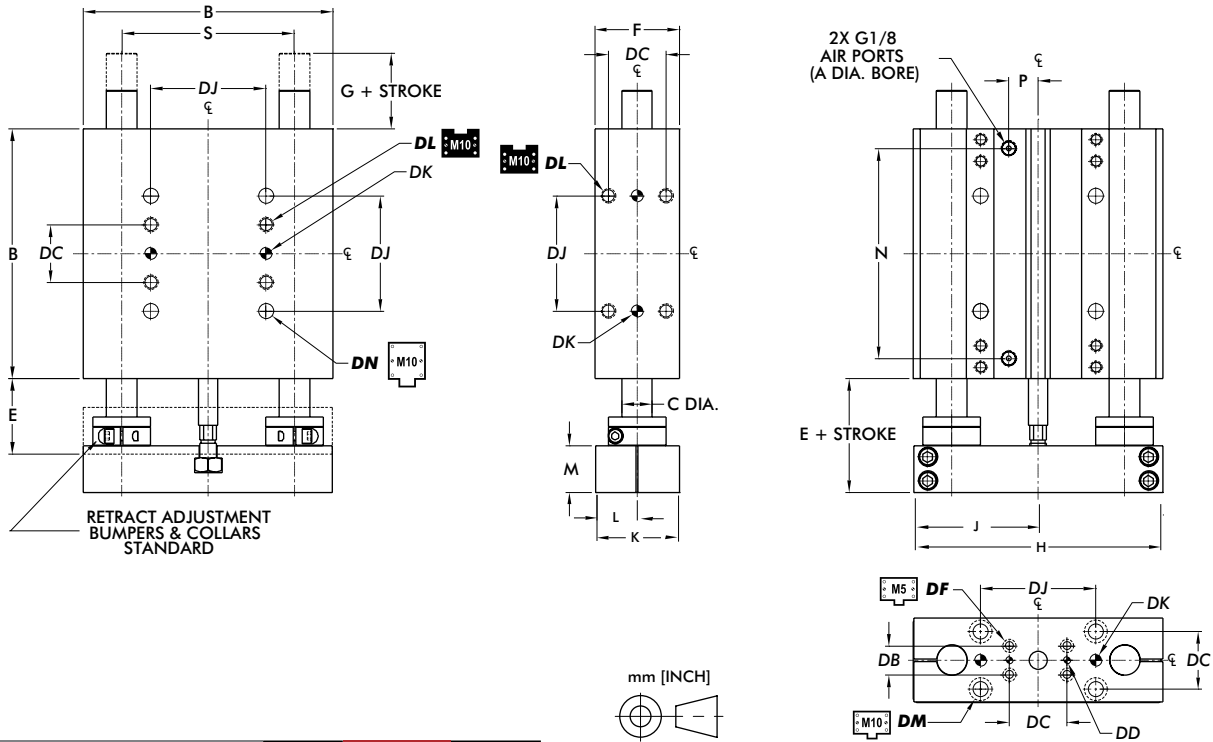

Pneumatic Accessories	Model	Part #	Qty/Unit
Cylinder Seal Kit (Buna-N)	20	SLKT-104	1
Cylinder Seal Kit (Viton®)	25	SLKT-104V	1

DIRECTCONNECT™ Mounting Pattern Dimensions (all sizes)									
DB	DC	DD	DF	DJ	DK	DL	DM	DN	
19.1 [0.750]	38.1 [1.500]	5mm H7 X 6 DP	CLEARANCE FOR M5	76.2 [3.000]	8mm H7 x 9.4 DP	M10 x 14.2 DP	CLR & C'BORE FOR M10		

Model	Basic Unit Dimensions															
	Bore Ø	Body Size	Shaft Ø	A	B	C	E	F	G	H	J	K	L	M	N	P
DLT-20M	38 [1 1/2]	165.1 [6.50]	20 [0.787]	49.8 [1.960]	55.9 [2.20]	24.4 [0.960]	164.6 [6.480]	82.0 [3.230]	55.4 [2.180]	27.4 [1.080]	30.7 [1.210]	138.9 [5.47]	19.5 [0.77]	114.30 [4.300]		
DLT-25M		190.5 [7.50]	25 [0.984]	55.1 [2.170]		29.7 [1.170]	190.0 [7.480]	94.7 [3.730]			36.1 [1.420]	164.3 [6.47]		133.35 [5.250]		

Dimensions in mm [in]

Loading Information

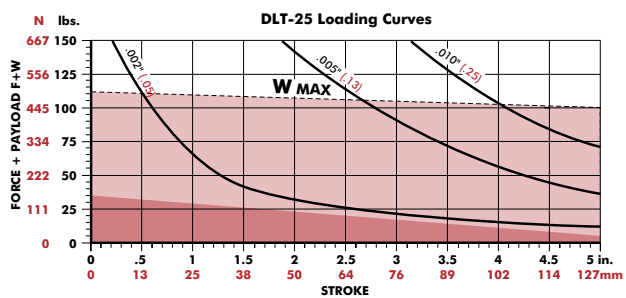
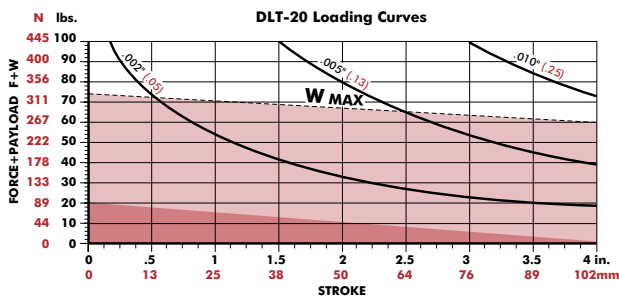

Shock Absorbers and Flow Controls are recommended for all applications

F=Externally applied force

W=Weight of payload

F+W=Total force

M=Maximum moment (in-lb. or N-m)

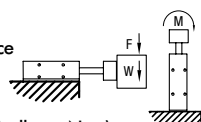

(W) in this range use **Single Shock** in retract directions

(W) in this range use **Bumpers or Cushioned Cylinder**

Shaded shock absorption ranges of horizontal payload (W) @ 80psi, flow controls fully open. For vertical applications do not exceed 1/2 of the recommended payload due to the additional acceleration effect of gravity.

Internal Air Cylinder Linear Thruster Slides | Dimensions and Technical Specifications

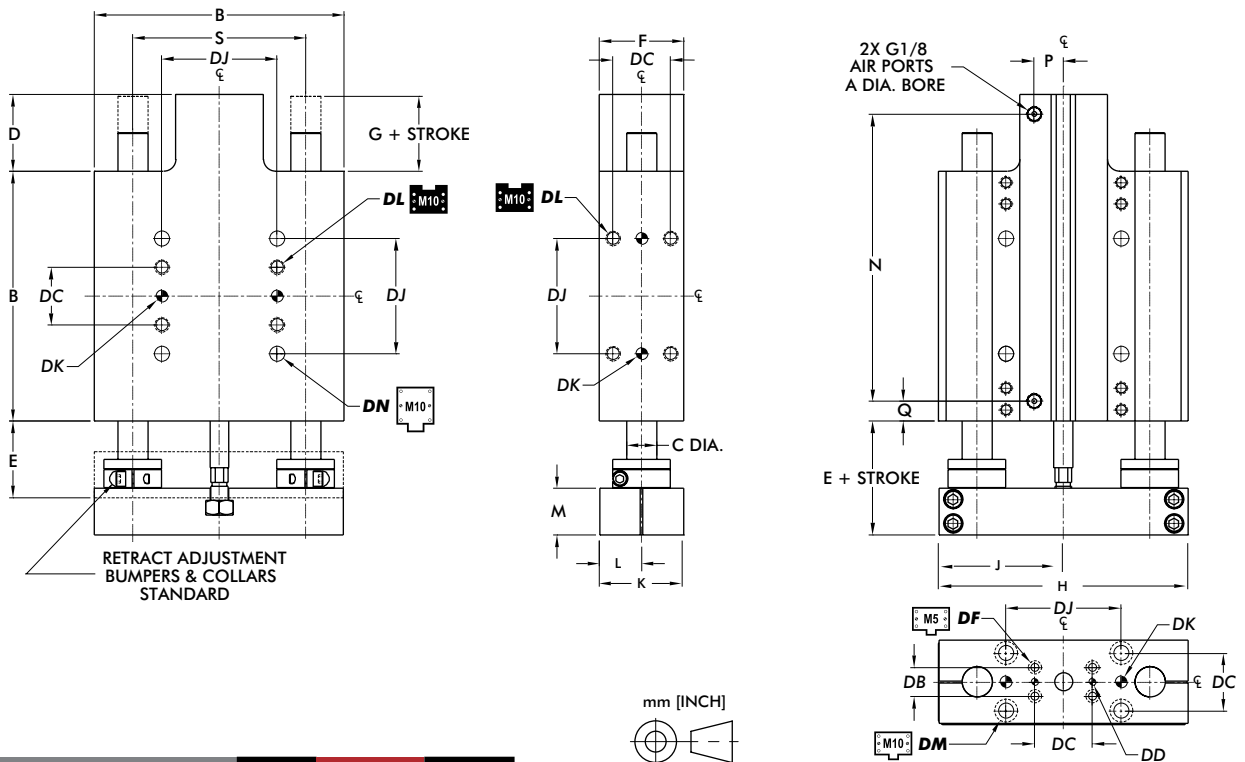

Pneumatic Accessories	Model	Part #	Qty/Unit
Cylinder Seal Kit (Buna-N)	20	SLKT-104	1
Cylinder Seal Kit (Viton®)	25	SLKT-104V	1

DIRECTCONNECT™ Mounting Pattern Dimensions (all sizes)									
DB	DC	DD	DF	DJ	DK	DL	DM	DN	
19.1 [0.750]	38.1 [1.500]	5mm H7 X 6 DP	CLEARANCE FOR M5	76.2 [3.000]	8mm H7 x 9.4 DP	M10 x 14.2 DP	CLR & C'BORE FOR M10		

Model	Basic Unit Dimensions															
	Bore Ø	Body Size	Shaft Ø	D	E	F	G	H	J	K	L	M	N	P	Q	S
DLT-20M	38 [1 1/2]	165.1 [6.50]	20 [0.787]	50.8 [2.00]	49.8 [1.960]	55.9 [2.20]	24.4 [0.960]	164.6 [6.480]	82.0 [3.230]	55.4 [2.180]	27.4 [1.080]	30.7 [1.210]	189.7 [7.469]	19.4 [0.77]	13.1 [0.52]	114.30 [4.500]
DLT-25M		190.5 [7.50]	25 [0.984]		55.1 [2.170]		29.7 [1.170]	190.0 [7.480]	94.7 [3.730]			36.1 [1.420]	215.1 [8.468]			133.35 [5.250]

Dimensions in mm [in]

Loading Information

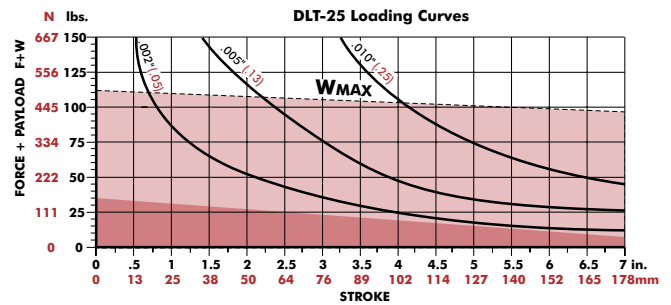
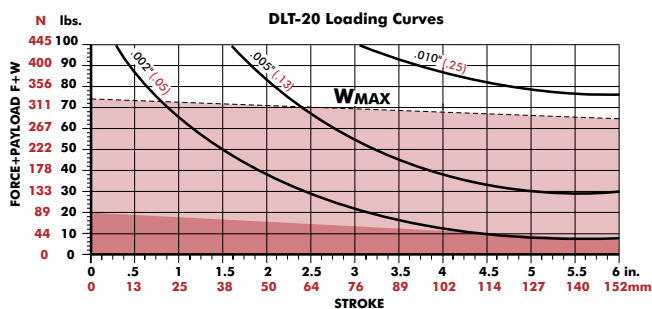

Shock Absorbers and Flow Controls are recommended for all applications

F=Externally applied force
 W=Weight of payload
 F+W=Total force
 M=Maximum moment (in-lb. or N-m)

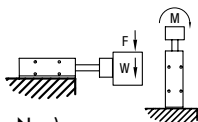

(W) in this range use Single Shock in retract directions (W) in this range use Bumpers or Cushioned Cylinder

Shaded shock absorption ranges of horizontal payload (W) @ 80psi, flow controls fully open. For vertical applications do not exceed 1/2 of the recommended payload due to the additional acceleration effect of gravity.

DLT SERIES - EXTERNAL AIR CYLINDER

External Air Cylinder Linear Thruster Slides | Features and Benefits | How To Order

Features:

- Bearing system for smooth operation
- Rugged design produces very reliable long life operation
- Replaceable air cylinder with adjustable cushions
- Non-powered Thrusters use customer supplied cylinders
- Urethane bumpers, hardened pads, oil wick
- Optional telescopic airlines transfers air to tooling
- DIRECTCONNECT™ mounting pattern
- Corrosion resistant shafting for corrosive environments
- Position sensing using inductive or magneto resistive sensors

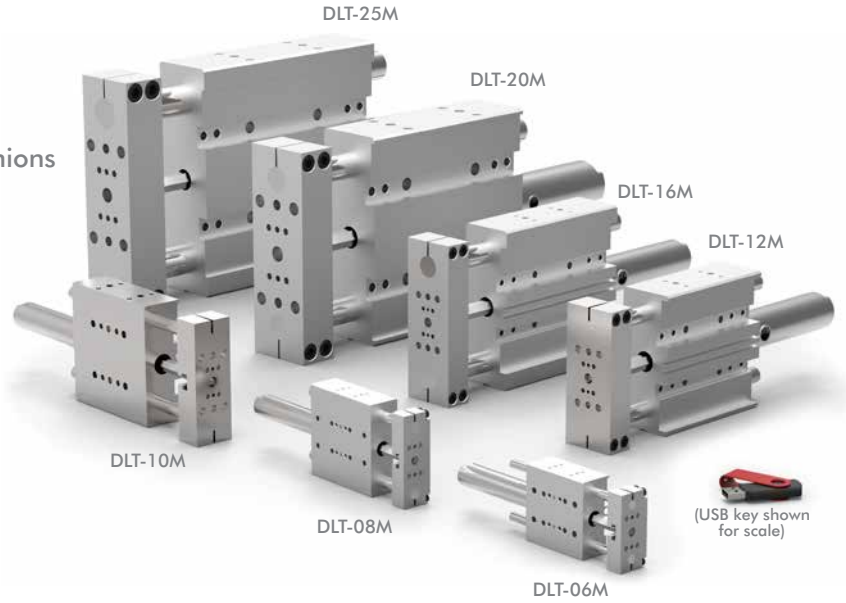

Applications:

- Machining and automation applications
- Harsh environment pick-and-place applications
- Gantry system applications

How To Order

Size	Styles Available	Style	Description
06M	T, U	T	Replaceable cylinder w/o adjustable air cushions
08M	T, U	A	Replaceable cylinder with adjustable air cushions
10M	A, U	N	Repairable VDMA cylinder w/adjustable air cushions
12M	A, U	R	Repairable locking VDMA cylinder w/adjustable air cushions
16M	A, U	U	Non-powered unit*
20M	N, R, U		*Without cylinder. Metric Units: Mount VDMA cylinder directly.
25M	N, R, U		

Base Model	Bearing	Shafting	Description
DLT	B	"Blank"	Precision Hardened
	C	S	Corrosion Resistant

*Not available on -06 or -08

Size	Style	Stroke* Metric (mm)
DLT-06M	T, U	10, 25, 40, 50, 75, 100, 125, 160
DLT-08M	T, U	10, 25, 40, 50, 75, 100, 125, 160, 175, 200
DLT-10M	A, U	25, 50, 80, 100, 125, 160, 200, 250, 300
DLT-12M	A, U	25, 50, 80, 100, 125, 160, 200, 250, 300, 320, 360, 400
DLT-16M	A, U	25, 50, 80, 100, 125, 160, 200, 250, 300, 320, 360, 400, 500
DLT-20M	N, R, U	25, 50, 80, 100, 125, 160, 200, 250, 300, 320, 360, 400, 500
DLT-25M	N, R, U	25, 50, 80, 100, 125, 160, 200, 250, 300, 320, 360, 400, 500

*Custom strokes available. Consult factory.

DLT SERIES - EXTERNAL AIR CYLINDER

External Air Cylinder Linear Thruster Slides | Accessories

Shock/Stop & Mounting Accessories	Model Numbers	Style	Part Number	Qty/Unit
Universal Mounting Kit (Stop/Shock)	06	All	OSAK-069	1-4
	08		OSAK-070	
Universal Mounting Kit (Stop/Shock/Sensor)	10		OSAK-055	
	12		OSAK-057	
	16		OSAK-059	
	20		OSAK-061	
	25		OSAK-063	
	06, 08		SHOK-030	
Shock Absorber (2 Max on -06)	10		SHOK-028	
	12, 16,		SHOK-010	
	20, 25		SHOK-029	
Adjustable Hard Stop	06, 08		DLT-0623	
	10, 12, 16, 20, 25		DLT-1023	
Urethane Bumper/Stop Collar Kit	06		OSAK-067	
	08	OSAK-068		
	10	OSAK-065		
	12	OSAK-066		
	16	OSAK-060		
	20	OSAK-062		
	25	OSAK-064		

Sensor Accessories	Model Numbers	Style	Part Number	Qty/Unit
Inductive Sensor Mounting Kit	06	T	OSMK-076	1
Inductive Sensor Mounting Kit	08		OSMK-077	
PNP Inductive Sensor with Quick Disconnect*	06, 08,	T	OISP-014	
NPN Inductive Sensor with Quick Disconnect*			OISN-014	
PNP Inductive Sensor with Quick Disconnect*	10, 12, 16, 20, 25	A, N, R	OISP-011	1-2
NPN Inductive Sensor with Quick Disconnect*			OISN-011	
PNP Magneto Resistive Sensor w/Qk Disconnect*	06, 08, 10, 12, 16	T, A	OHSP-005	
NPN Magneto Resistive Sensor w/Qk Disconnect*			OHSN-005	
PNP Magneto Resistive Sensor w/Qk Disconnect*	20, 25	N, R	OHSP-020	
Quick Disconnect 2 Meter Cable Length*	All Model	All	CABL-010	
Quick Disconnect 5 Meter Cable Length*			CABL-013	
Cable Extension Cord 1M Length*	All Models	All	CABL-015	
Cable Extension Cord 2M Length*			CABL-016	

Pneumatic Accessories	Model Numbers	Style	Part Number	Qty/Unit
VDMA Cylinder Mounting Kit	20, 25	U	ODLT-004	1
G1/8 Telescopic Airlines (up to 160mm)	10, 12, 16, 20, 25	All	OTAL-045	1-4
G1/8 Telescopic Airlines (up to 300mm)			OTAL-046	
G1/8 Telescopic Airlines (up to 450mm)			OTAL-047	
G1/8 Telescopic Airlines (up to 600mm)			OTAL-048	
M5 Adjustable Flow Control			06, 08	VLVF-008
G1/8 Adjustable Flow Control	10, 12, 16, 20, 25		VLVF-005	

*Sensor and cable sold separately.

See page GR-LIN-36 for Accessory Mounting Technical Data

DLT SERIES - EXTERNAL AIR CYLINDER

External Air Cylinder Linear Thruster Slides | Technical Specifications

Specifications	Units	06	08	10	12	16	20	25
Max. Air Pressure	bar [psi]	7 [100]						
Thrust Force @ 5.5 bar [80psi]	N [lbs]	111 [20]	89 [20]	173 [35]	270 [70]	270 [70]	443 [140]	443 [140]
Weight (basic unit)	kg [lb]	0.24 [0.53]	0.40 [0.88]	1.05 [2.12]	1.64 [3.42]	2.11 [4.47]	6.3 [14.3]	8.5 [19.2]
Additional Weight per Stroke	g/mm [lbs/in]	0.88 [0.05]	1.43 [0.07]	1.2 [0.09]	2.9 [0.15]	4.2 [0.23]	7.9 [0.53]	10.7 [0.68]
Cylinder Bore Ø	mm [in]	16 [0.563]		20 [0.787]	25 [0.984]		32 [1.26]	
Shaft Ø	mm [in]	6 [0.236]	8 [0.315]	9.5 [0.375]	12 [0.472]	16 [0.630]	20 [0.787]	25 [0.984]
Max (M) Vertical Motion	Nm [in-lbs]	0.6 [5]	1.3 [10]	--	--	--	--	--
Min. Air Pressure to Release Cyl. Lock -R	bar [psi]	--	--	--	--	--	4 [60]	
Holding Force of Lock Mechanism -R	N [lbs]	--	--	--	--	--	550 [123]	

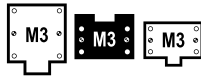

External Air Cylinder Linear Thruster Slides | Dimensions and Technical Specifications

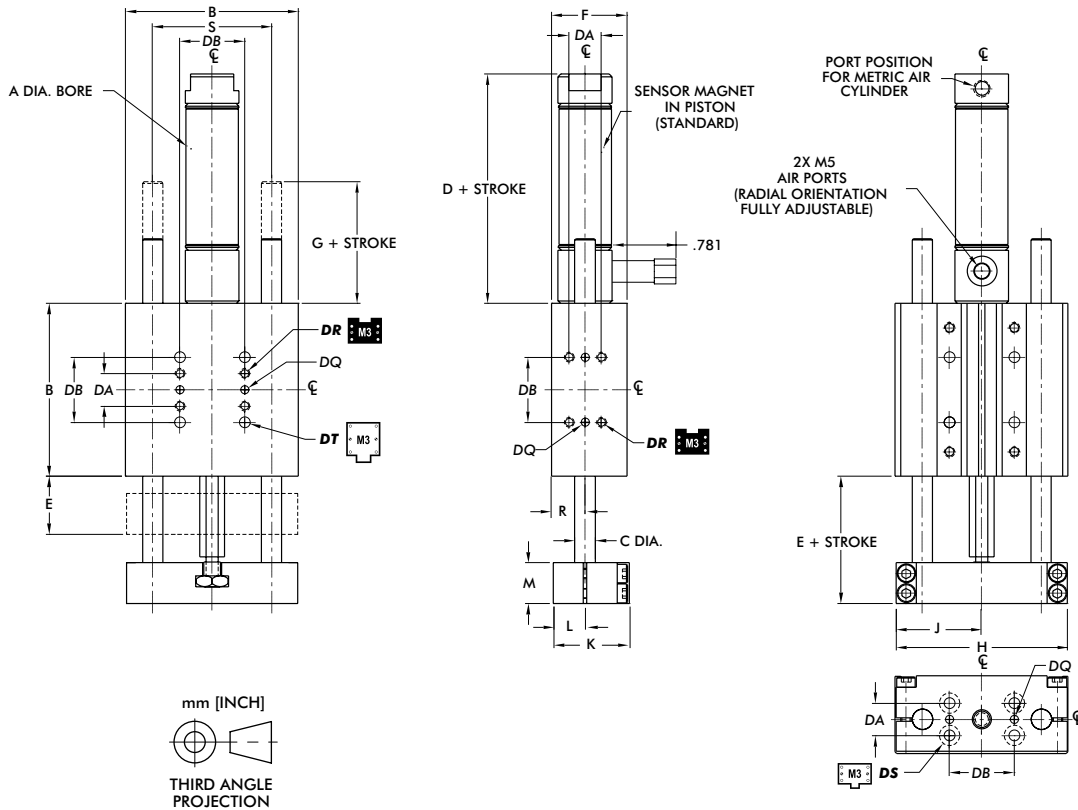

DIRECTCONNECT™ Mounting Pattern Dimensions (all sizes)

DA	DB	DQ	DR	DS	DT
9.5 [0.375]	19.1 [0.750]	3H7 X 2 DP	M3 x 6 DP	CLR & C'BORE FOR M3	CLR & C'BORE FOR M3

Model	Bore Ø Body Size Shaft Ø			Basic Unit Dimensions										
	A	B	C	D	E	F	G	H	J	K	L	M	R	S
DLT-06M	16 [0.63]	50.8 [2.00]	6.0 [0.236]	54.9 [2.16]	19.9 [0.783]	22.4 [0.88]	16.7 [0.66]	50.3 [1.980]	25.1 [0.990]	22.2 [0.875]	9.3 [0.365]	11.9 [0.470]	9.9 [0.390]	34.93 [1.375]
DLT-08M		63.5 [2.50]	8.0 [0.315]				10.4 [0.41]	62.7 [2.470]	31.4 [1.235]					44.45 [1.750]

Dimensions in mm [in]

Loading Information

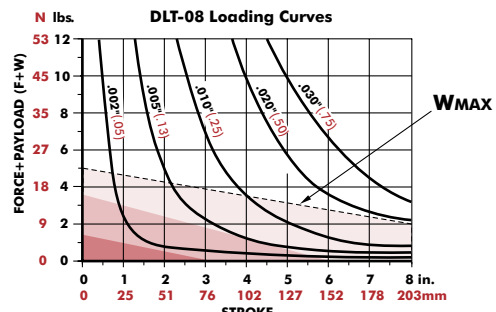
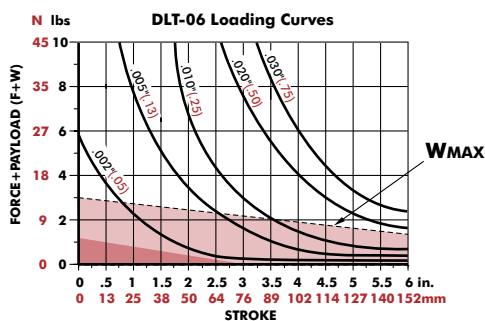

F=Externally applied force

W=Weight of payload

F+W=Total force

M=Maximum moment (in-lb. or N-m)

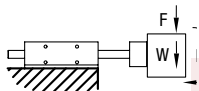

Shock Absorbers and Flow Controls are recommended for all applications

Use Double Shocks in both directions

Use Single Shock in both directions

Use Bumpers or Cushioned Cylinder

Shaded shock absorption ranges of horizontal payload (W) @ 80psi, flow controls fully open. For vertical applications do not exceed 1/2 of the recommended payload due to the additional acceleration effect of gravity.

DLT-10/12/16M-A, U



External Air Cylinder Linear Thruster Slides | Dimensions and Technical Specifications

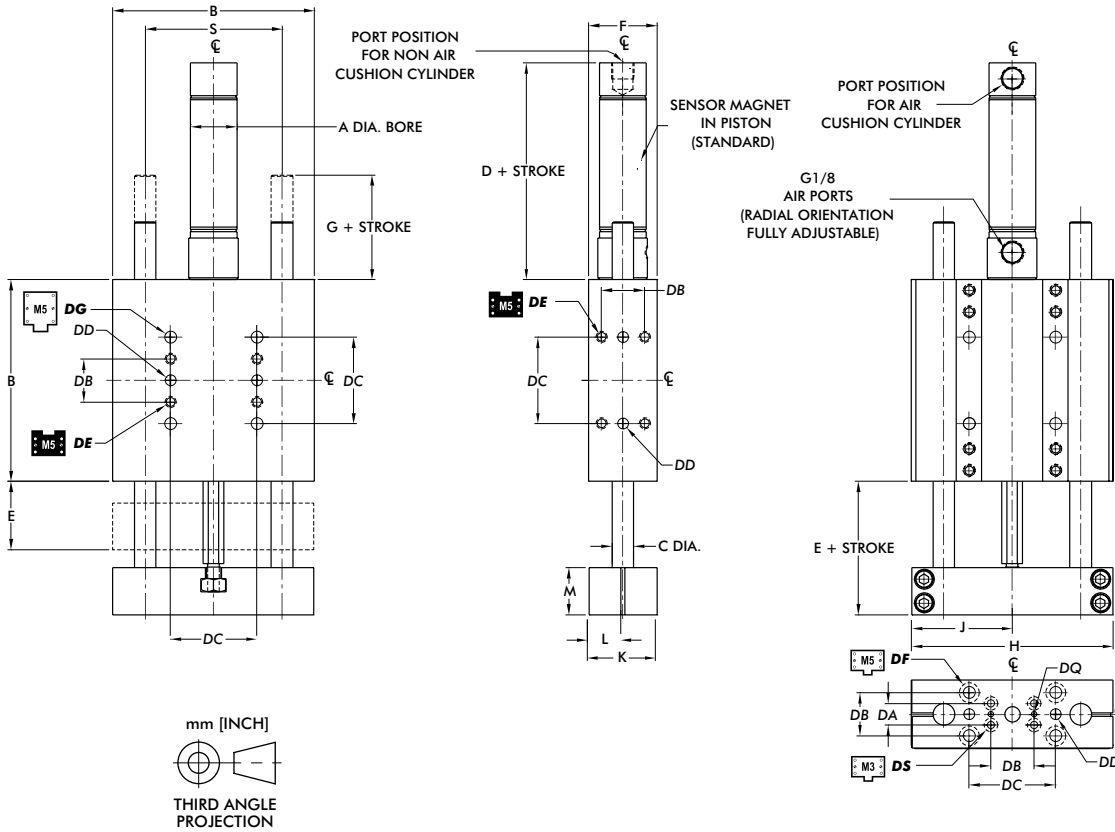

DIRECTCONNECT™ Mounting Pattern Dimensions (all sizes)									
DA	DB	DC	DD	DE	DF	DG	DQ	DS	
9.5 [0.375]	19.1 [0.750]	38.1 [1.500]	5mm H7 X 6 DP	M5 X 8.5 DP	CLEARANCE FOR M5		3H7 X 2 DP	CLR & C'BORE FOR M3	

Model	Bore Ø	Body Size	Shaft Ø	Basic Unit Dimensions									
				A	B	C	D	E	F	G	H	J	K
DLB-10M	20 [3/4]	88.9 [3.50]	9.5 [0.375]	88.0 [2.91]	33.4 [1.313]	30.2 [1.19]	20.8 [0.82]	88.6 [3.490]	44.2 [1.740]	29.9 [1.178]	14.8 [0.584]		60.33 [2.375]
DLB-12M	25 [1]	101.6 [4.00]	12.0 [0.472]	91.5 [2.88]	34.9 [1.375]	41.4 [1.63]	19.3 [0.76]	101.2 [3.985]	50.4 [1.985]	41.0 [1.615]	20.4 [0.802]	20.7 [0.813]	69.85 [2.750]
DLB-16M		120.7 [4.75]	16.0 [0.630]					120.3 [4.735]	59.9 [2.360]				82.55 [3.250]

Dimensions in mm [in]

Loading Information

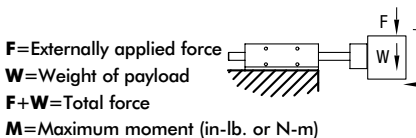
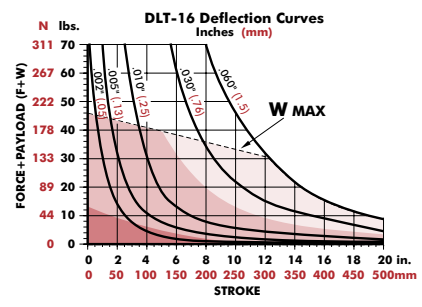
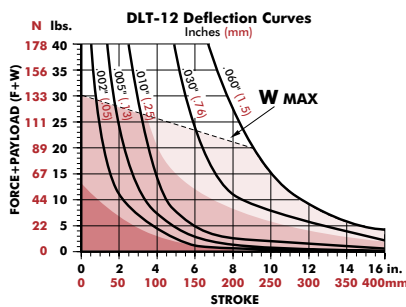
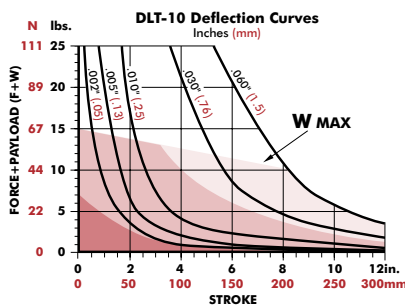

Shock Absorbers and Flow Controls are recommended for all applications

- Use **Double Shocks** in both directions
- Use **Single Shock** in both directions
- Use **Bumpers or Cushioned Cylinder**

Shaded shock absorption ranges of horizontal payload (W) @ 80psi, flow controls fully open. For vertical applications do not exceed 1/2 of the recommended payload due to the additional acceleration effect of gravity.

External Air Cylinder Linear Thruster Slides | Dimensions and Technical Specifications

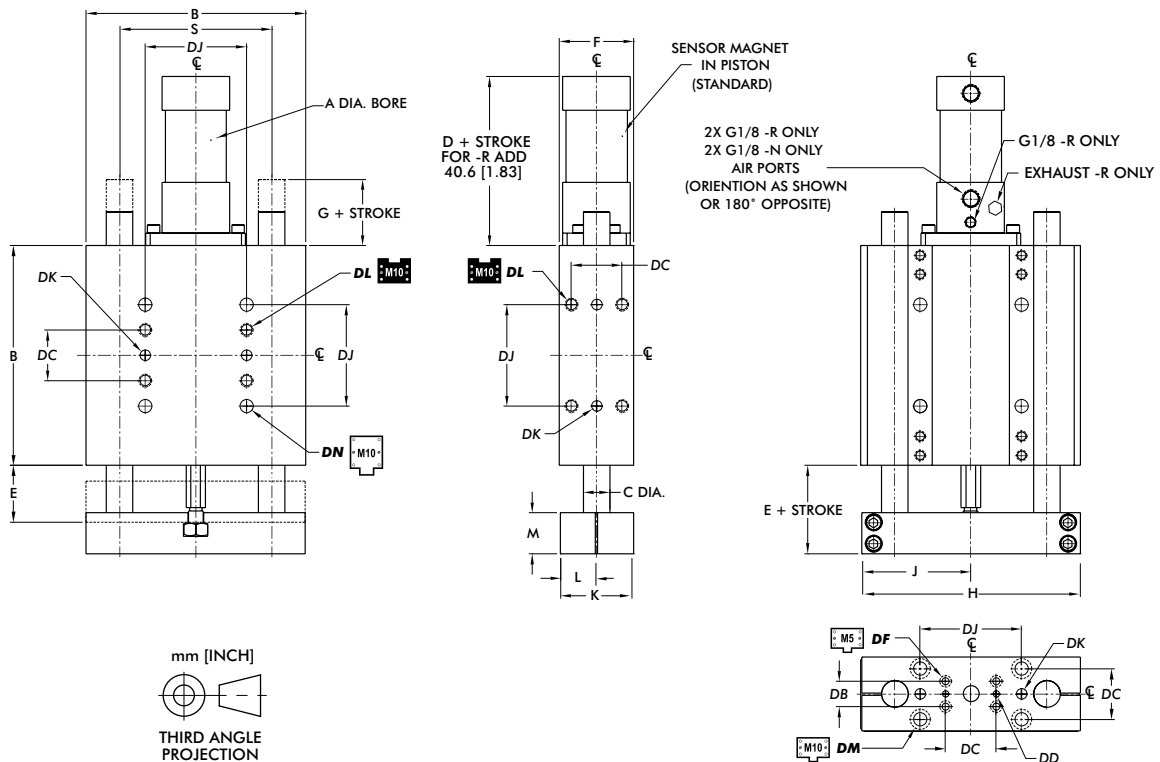

DIRECTCONNECT™ Mounting Pattern Dimensions (all sizes)

DB	DC	DD	DF	DJ	DK	DL	DM	DN
19.1 [0.750]	38.1 [1.500]	5mm H7 X 6 DP	CLEARANCE FOR M5	76.2 [3.000]	8mm H7 x 9.4 DP	M10 x 14.2 DP	CLR & C'BORE FOR M10	

Model	Bore Ø			Basic Unit Dimensions									
	A	B	C	D	E	F	G	H	J	K	L	M	S
DLB-20M	32 [1 1/2]	165.1 [6.50]	20 [0.787]	107.7 [4.01]	49.8 [1.960]	55.9 [2.20]	24.4 [0.960]	164.6 [6.480]	82.0 [3.230]	55.4 [2.180]	27.4 [1.080]	30.7 [1.210]	114.30 [4.500]
DLB-25M		190.5 [7.50]	25 [0.984]		55.1 [2.170]		29.7 [1.170]	190.0 [7.480]	94.7 [3.730]			36.1 [1.420]	133.35 [5.250]

Dimensions in mm [in]

Loading Information

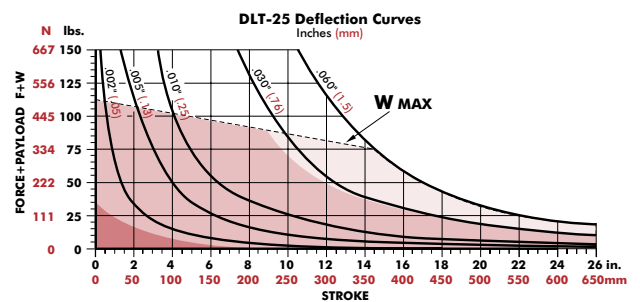
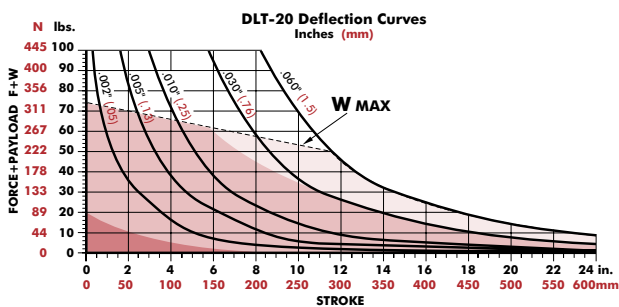

F=Externally applied force
W=Weight of payload
F+W=Total force
M=Maximum moment (in-lb. or N-m)

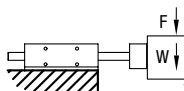

Shock Absorbers and Flow Controls are recommended for all applications

Use Double Shocks in both directions

Use Single Shock in both directions

Use Bumpers or Cushioned Cylinder

Shaded shock absorption ranges of horizontal payload (W) @ 80psi, flow controls fully open. For vertical applications do not exceed 1/2 of the recommended payload due to the additional acceleration effect of gravity.

BASE SLIDE ACCESSORIES

Linear Slides | Accessory Mounting Technical Data

DLB-B, L Internally Powered Base Slides

Shock Absorbers

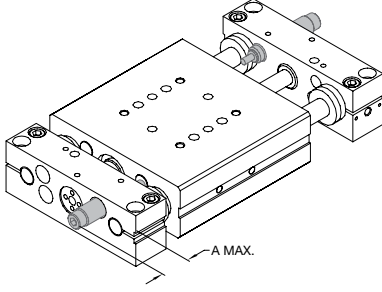

Adjustable Hard Stops

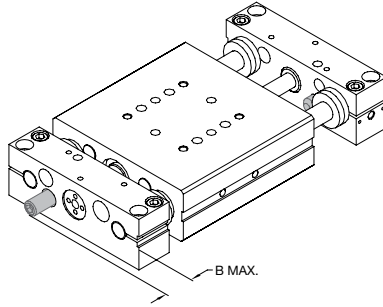

Inductive Proximity Sensors

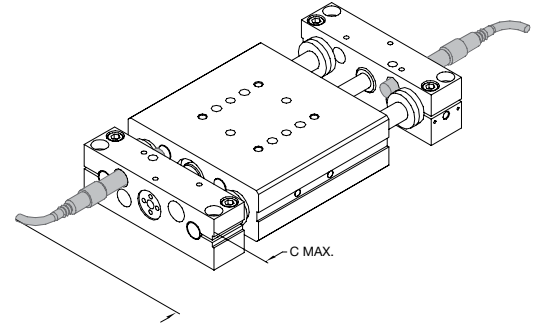

Telescopic Airlines

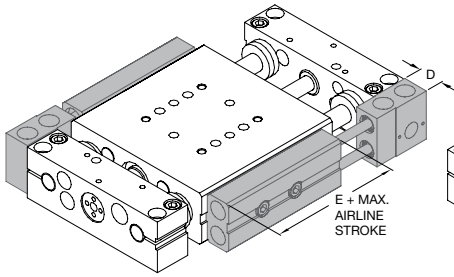

Flow Controls

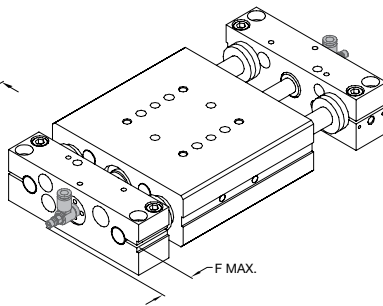

Model	A	B	C	D	E	F
DLB-06M	13.5 [0.53]	10.2 [0.40]	45.7 [1.8]	--	--	25.9 [1.02]
DLB-08M				--	--	
DLB-10M	17.8 [0.70]					
DLB-12M	24.1 [0.95]	11.9 [0.47]	63.5 [2.5]			
DLB-16M				14.7 [0.577]	91.4 [3.60]	31.8 [1.25]
DLB-20M	51.6 [2.03]		53.8 [2.1]			
DLB-25M	46.2 [1.82]	2.5 [0.10]	48.3 [1.9]			

Dimensions in mm [in]

DLB-T, A, R, U Externally Powered Base Slides

Shock Absorbers

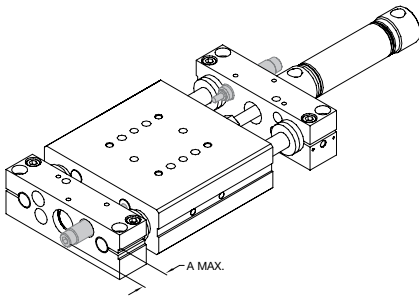

Adjustable Hard Stops

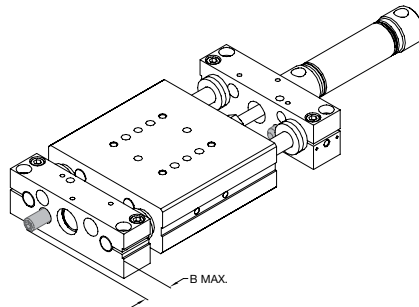

Telescoping Airlines & Flow Controls

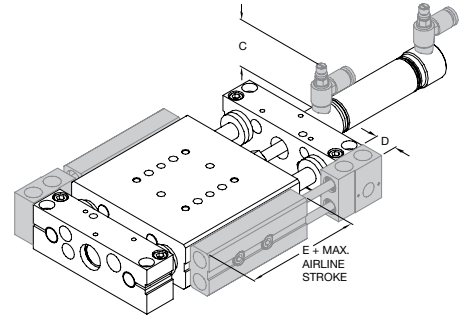

Inductive Proximity Sensors

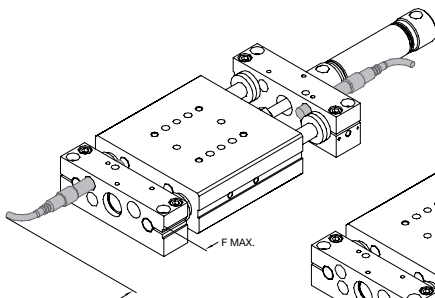

Magneto Resistive Sensors

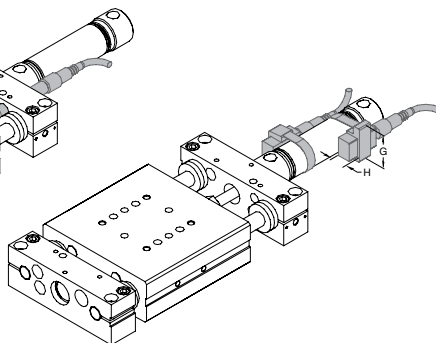

Model	A	B	C	D	E	F	G	H
DLB-06M	13.5 [0.53]	10.2 [0.40]	25.9 [1.02]	--	--	45.7 [1.8]		
DLB-08M				--	--			
DLB-10M	17.8 [0.70]							
DLB-12M	24.1 [0.95]	11.9 [0.47]				63.5 [2.5]	25.4 [1.00]	10.9 [0.43]
DLB-16M			31.8 [1.25]	14.7 [0.577]	91.4 [3.60]			
DLB-20M	51.6 [2.03]					53.8 [2.12]		
DLB-25M	46.2 [1.82]	2.5 [0.10]				48.3 [1.90]		

Dimensions in mm [in]

LINEAR THRUSTER ACCESSORIES

Linear Slides | Accessory Mounting Technical Data

DLT-B, E, L Internally Powered Thruster Slides

Urethane Bumpers & Clamp Collars (DLT-E, L only)

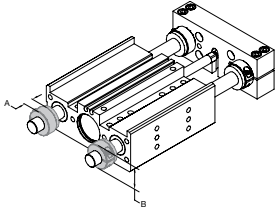

Adjustable Hard Stop & Shock Absorbers

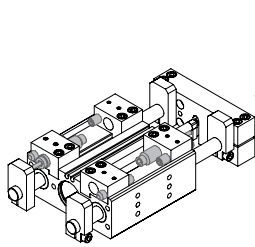

Universal Mounting Kit

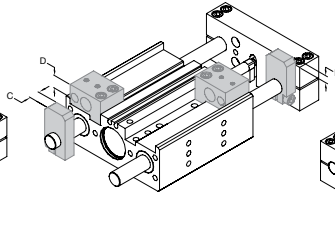

Telescoping Airlines (DLT-E, L only)

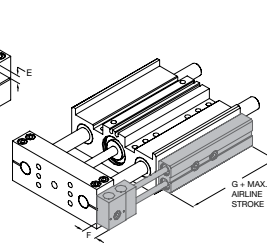

Base Flange Kit (DLT-B only)

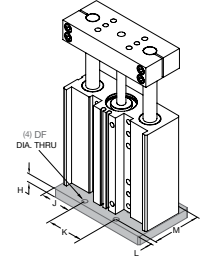

Inductive Proximity Sensors

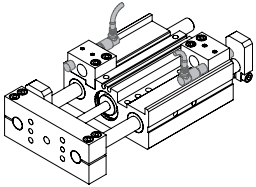

Magneto Resistive Sensors

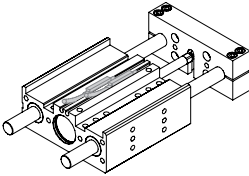

Model	A	B	C	D	E	F	G	H	J	K	L	M
DLT-06M	6.0 [0.236]	12 [0.470]	6.4 [0.250]	7.9 [0.310]	6.9 [0.270]	--	--	3.2 [0.125]	8.0 [0.313]	35 [1.376]	3.2 [0.125]	28.6 [1.125]
DLT-08M		16 [0.630]							14.3 [0.563]			
DLT-10M	8.7 [0.343]	22.1 [0.87]	9.5 [0.375]	12.2 [0.480]	8.1 [0.320]				25.4 [1.000]			38.1 [1.500]
DLT-12M	9.5 [0.375]	23.9 [0.95]		11.4 [0.450]	5.8 [0.230]			9.0 [0.355]	32.5 [1.281]	38.1 [1.500]	4.8 [0.188]	50.8 [2.000]
DLT-16M	11.1 [0.437]	33.3 [1.31]	11.1 [0.437]		8.6 [0.340]	14.7 [0.577]	91.4 [3.60]		42.1 [1.656]			
DLT-20M		38.1 [1.50]							44.5 [1.750]	76.2 [3.000]	9.5 [0.375]	76.2 [3.000]
DLT-25M	12.7 [0.500]	44.5 [1.75]	12.7 [0.500]	22.4 [0.920]	17.0 [0.67]			12.2 [0.480]	57.2 [2.250]			

Dimensions in mm [in]

DLT-T, A, R, U Externally Powered Thruster Slides

Urethane Bumpers & Clamp Collars

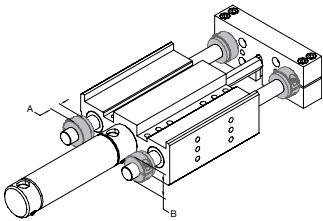

Adjustable Hard Stop & Shock Absorbers

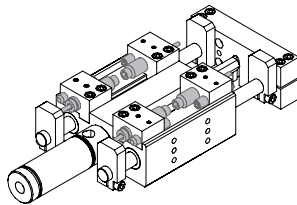

Universal Mounting Kit

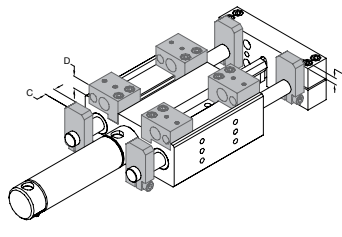

Telescoping Airlines & Flow Controls

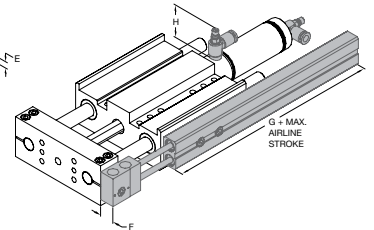

Inductive Proximity Sensors

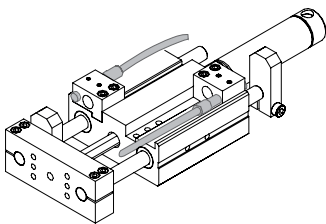

Magneto Resistive Sensors

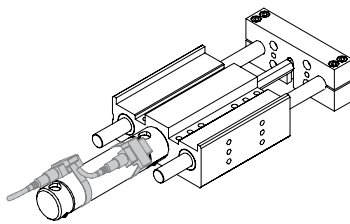

Model	A	B	C	D	E	F	G	H
DLT-06M	6.0 [0.236]	12.0 [0.47]	6.4 [0.250]	7.9 [0.31]	6.9 [0.27]	--	--	46.2 [1.82]
DLT-08M		16.0 [0.63]						
DLT-10M	8.7 [0.343]	22.1 [0.87]	9.5 [0.375]	12.2 [0.480]	8.1 [0.320]			
DLT-12M	9.5 [0.375]	23.9 [0.95]		11.4 [0.450]	5.8 [0.230]			
DLT-16M	11.1 [0.437]	33.3 [1.31]	11.1 [0.437]		8.6 [0.340]	14.7 [0.577]	91.4 [3.60]	28.4 [1.12]
DLT-20M		38.1 [1.50]						
DLT-25M	12.7 [0.500]	44.5 [1.75]	12.7 [0.500]	23.4 [0.92]	17.0 [0.670]			

Dimensions in mm [in]

DLM SERIES

Miniature Rail Thruster Slide | Features and Benefits | How To Order

Features:

- Compact high reliability bearing design
- Excellent part position repeatability
- Double bearings -**D** for longer strokes, greater load and moment capacity
- Internal Delrin® extend and retract stops -**P** for increased repeatability
- Sense up to 8 positions with 4 adjustable magneto resistive sensors
- Multiple tapped air ports on each side, rear and bottom of body
- Thru-body mounting and DIRECTCONNECT™ thru tapped and dowel mounting, on tool plate and body
- Viton® seals for operation in high temperature environments



Applications:

- Precision applications
- Small parts handling

How To Order

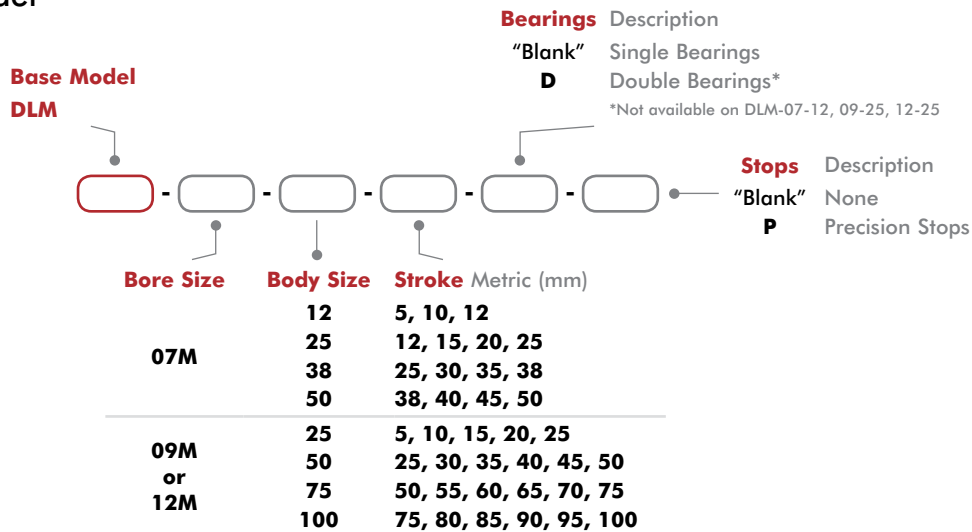

Accessories

Sensor Accessories	Model Numbers	Part Number	Qty/Unit
PNP Magneto Resistive Sensor Short Barrel (with Qk. Disc.)*	All Models	OHSP-017	1-4
NPN Magneto Resistive Sensor Short Barrel (with Qk. Disc.)*	All Models	OHSN-017	1-4
PNP Magneto Resistive Sensor 90° Barrel (with Qk. Disc.)*	All Models	OHSP-011	1-4
NPN Magneto Resistive Sensor 90° Barrel (with Qk. Disc.)*	All Models	OHSN-011	1-4
Quick Disconnect 2 Meter Cable Length*	All Models	CABL-010	1-4
Quick Disconnect 5 Meter Cable Length*	All Models	CABL-013	1-4
Pneumatic Accessories	Model Numbers	Part Number	Qty/Unit
Adjustable Flow Control	All Models	VLFL-008	1-2
Seal Kits	See Datasheets		1

*Sensor and cable sold separately.

Miniature Rail Thruster Slide | Technical Specifications

Specifications	Units	DLM-07M-12	DLM-07M-25	DLM-07M-38	DLM-07M-50
Thrust Force F @ 7 bar [100 psi]	N [lbs]	66 [15]			
Max. Stroke	mm [in]	12 [0.50]	25 [1.00]	38 [1.50]	50 [2.00]
Stroke Reduction (return)	mm [in]	5 [0.19]			
Weight	kg [lbs]	0.13 [0.28]	0.16 [0.35]	0.20 [0.43]	0.23 [0.50]
Max. Payload W	kg [lbs]	0.45 [1.0]			
Max. Payload W (-P option)	kg [lbs]	0.23 [0.5]			
Cylinder Bore \varnothing	mm [in]	0.11 [0.437]			
Temperature Range	°C [°F]	-35°~80° [-30°~180°]			
Actuation (per 25mm of travel)	sec	0.07			
Linear Accuracy (per 25mm of travel)	mm [in]	±0.005 [±0.0001]			
Repeatability (-P option)	mm [in]	±0.08 [±0.003]			
Pressure Range	bar [psi]	1.4-7 [20-100]			
Valve to Actuate Double Acting		4-way, 2-position			

Specifications	Units	DLM-09M-25	DLM-09M-50	DLM-09M-75	DLM-09M-100
Thrust Force F @ 7 bar [100 psi]	N [lbs]	138 N [31 lbs]			
Max. Stroke	mm [in]	25 [1.00]	50 [2.00]	75 [3.00]	100 [4.00]
Stroke Reduction (return)	mm [in]	5 [0.19]			
Weight	kg [lbs]	0.49 [1.08]	0.64 [1.41]	0.81 [1.78]	0.97 [2.13]
Max. Payload W	kg [lbs]	0.90 [2.0]			
Max. Payload W (-P option)	kg [lbs]	0.45 [1.0]			
Cylinder Bore \varnothing	mm [in]	16 [0.630]			
Temperature Range	°C [°F]	-35°~80° [-30°~180°]			
Actuation (per 25mm of travel)	sec	0.10			
Linear Accuracy (per 25mm of travel)	mm [in]	±0.005 [±0.0001]			
Repeatability (-P option)	mm [in]	±0.08 [±0.003]			
Pressure Range	bar [psi]	1.4-7 [20-100]			
Valve to Actuate Double Acting		4-way, 2-position			

Specifications	Units	DLM-12M-25	DLM-12M-50	DLM-12M-75	DLM-12M-100
Thrust Force F @ 7 bar [100 psi]	N [lbs]	230 [51]			
Max. Stroke	mm [in]	25 [1.00]	50 [2.00]	75 [3.00]	100 [4.00]
Stroke Reduction (return)	mm [in]	5 [0.19]			
Weight	kg [lbs]	0.54 [1.18]	0.65 [1.43]	1.82 [1.80]	1.02 [2.25]
Max. Payload W	kg [lbs]	1.81 [4.0]			
Max. Payload W (-P option)	kg [lbs]	0.90 [2.0]			
Cylinder Bore \varnothing	mm [in]	22 [0.813]			
Temperature Range	°C [°F]	-35°~80° [-30°~180°]			
Actuation (per 25mm of travel)	sec	0.14			
Linear Accuracy (per 25mm of travel)	mm [in]	±0.005 [±0.0001]			
Repeatability (-P option)	mm [in]	±0.08 [±0.003]			
Pressure Range	bar [psi]	1.4-7 [20-100]			
Valve to Actuate Double Acting		4-way, 2-position			



Miniature Rail Thruster Slide | Dimensions and Technical Specifications

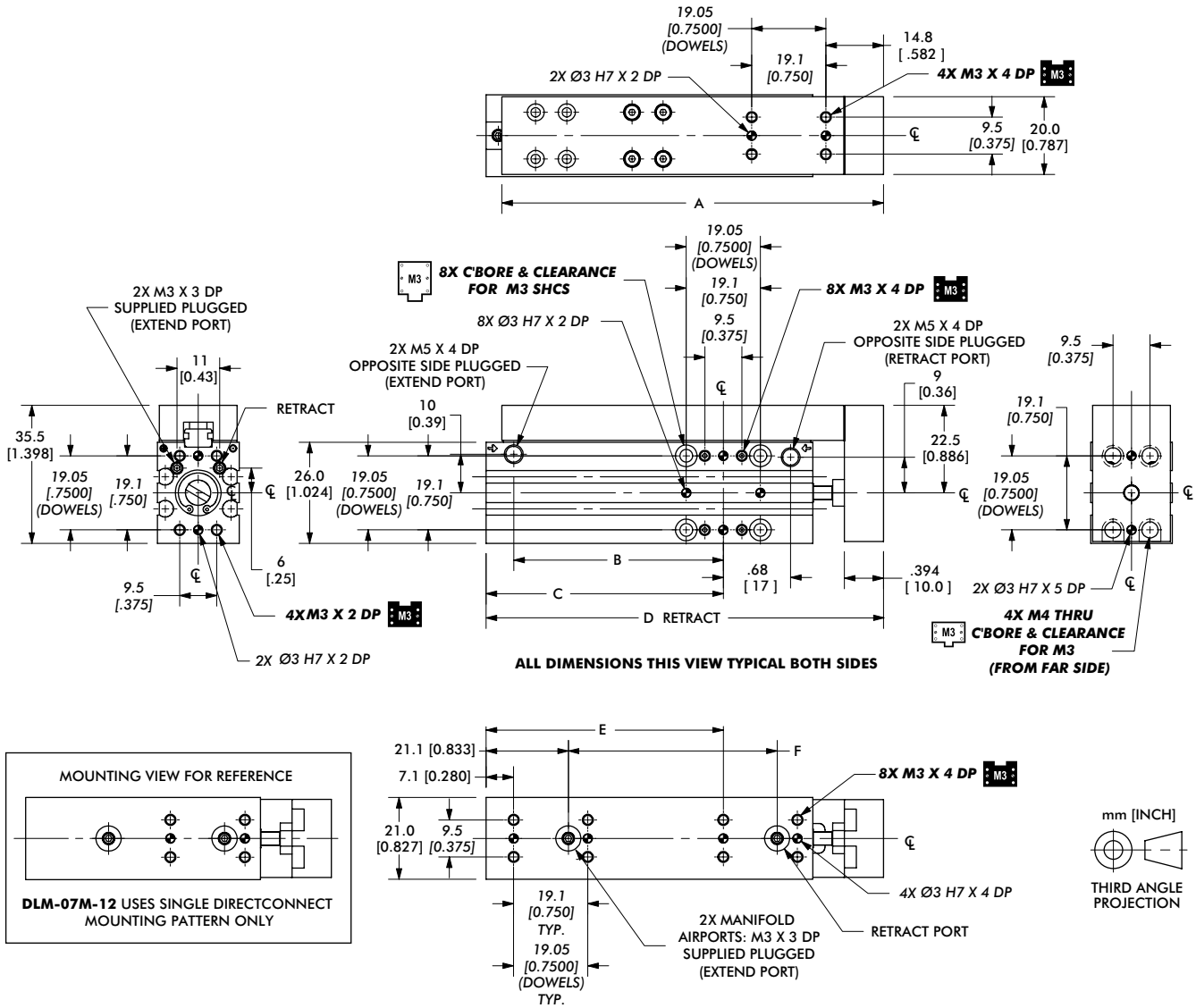

Seal Repair Kits	Order #
Buna-N Seal Repair Kit	SLKT-236
Manifold Seal Repair Kit	SLKT-239

Model	A	B	C	D	E	F	L (single bearing)	L (double bearing)
DLM-07M-12	66.0 [2.599]	30 [1.18]	37.0 [1.456]	78 [3.08]	37.0 [1.456]	29.6 [1.167]	53 [2.10]	--
DLM-07M-25	98.0 [3.859]	54 [2.12]	61.0 [2.401]	102 [4.02]	60.9 [2.401]	53.6 [2.112]	61 [2.39]	73 [2.87]
DLM-07M-38	111.0 [4.370]	67 [2.63]	74.0 [2.913]	115 [4.53]	74.0 [2.913]	66.6 [2.624]	74 [2.90]	86 [3.38]
DLM-07M-50	123.0 [4.843]	79 [3.10]	86.0 [3.385]	127 [5.00]	86.0 [3.385]	78.6 [3.096]	86 [3.37]	98 [3.86]

Dimensions in mm [in]

Loading Information

Forces shown for single bearing units. Values 2X for double bearings -D option.

DLM-07	Static
Maximum Tensile T	490 N [110 lbs]
Maximum Compressive C	490 N [110 lbs]
Maximum Moment M_x	5.1 Nm [45 in-lbs]
Maximum Moment M_y	3.2 Nm [28 in-lbs]
Maximum Payload W	3.2 Nm [28 in-lbs]
Distance to Bearing Centerline	L (see chart above)

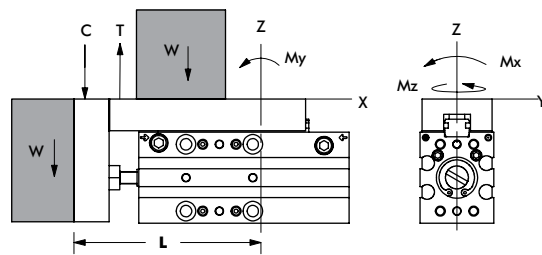

Flow Controls are recommended for all applications

Miniature Rail Thruster Slide | Dimensions and Technical Specifications

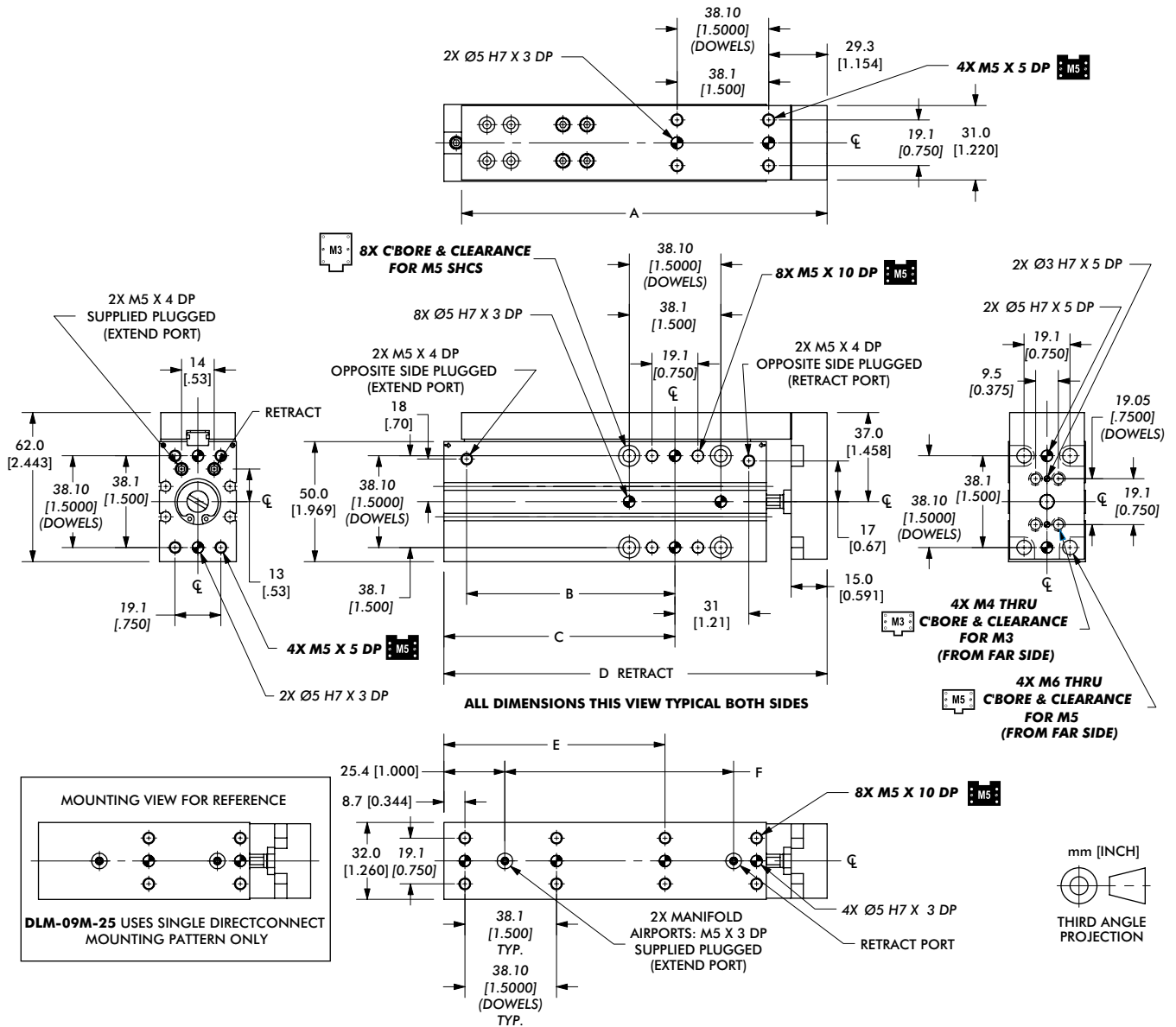

Model	A	B	C	D	E	F	L (single bearing)	L (double bearing)
DLM-09M-25	102.0 [4.016]	41 [1.60]	50.1 [1.973]	113 [4.46]	45.9 [1.809]	49.1 [1.934]	86 [3.40]	--
DLM-09M-50	152.0 [5.985]	87 [3.41]	96.1 [3.784]	159 [6.27]	91.9 [3.620]	95.1 [3.745]	105 [4.13]	121 [4.75]
DLM-09M-75	173.0 [6.811]	112 [4.39]	121.1 [4.768]	184 [7.26]	116.9 [4.604]	120.1 [4.729]	126 [4.95]	142 [5.58]
DLM-09M-100	202.0 [7.953]	137 [5.38]	146.1 [5.752]	209 [8.24]	138.9 [5.557]	145.1 [5.713]	155 [6.10]	171 [6.72]

Dimensions in mm [in]

Loading Information

Forces shown for single bearing units. Values 2X for double bearings -D option.

DLM-09	Static
Maximum Tensile T	735 N [165 lbs]
Maximum Compressive C	735 N [165 lbs]
Maximum Moment M_x	9.6 Nm [84 in-lbs]
Maximum Moment M_y	6.4 Nm [56 in-lbs]
Maximum Payload W	6.4 Nm [56 in-lbs]
Distance to Bearing Centerline	L (see chart above)

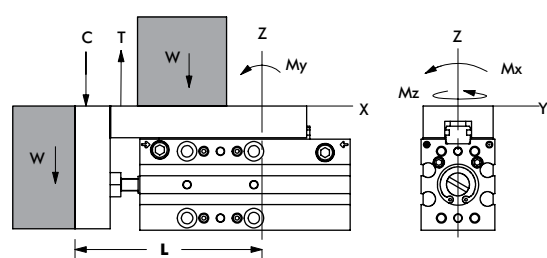

Flow Controls are recommended for all applications

Miniature Rail Thruster Slide | Dimensions and Technical Specifications

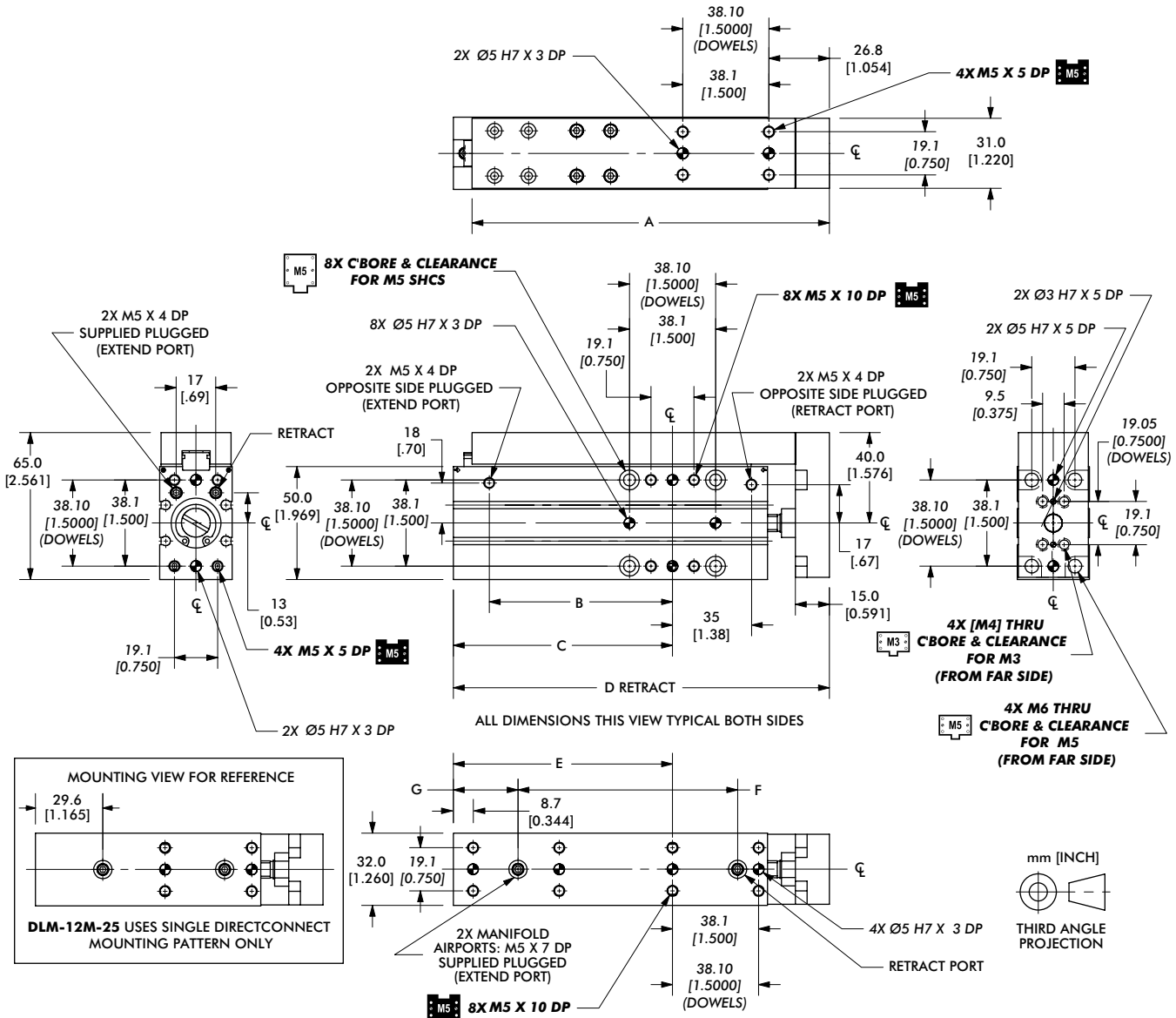

Seal Repair Kits	Order #
Buna-N Seal Repair Kit	SLKT-238
Manifold Seal Repair Kit	SLKT-240

Model	A	B	C	D	E	F	G	L (single bearing)	L (double bearing)
DLM-12M-25	105.0 [4.134]	41 [1.62]	56.9 [2.242]	126 [4.97]	56.9 [2.242]	53.5 [2.108]	29.6 [1.165]	88 [3.45]	--
DLM-12M-50	158.0 [6.221]	81 [3.19]	96.9 [3.816]	166 [6.55]	96.9 [3.816]	97.1 [3.824]		104 [4.10]	122 [4.82]
DLM-12M-75	186.0 [7.323]	108 [4.25]	123.9 [4.879]	193 [7.61]	123.9 [4.879]	124.1 [4.887]	28.6 [1.125]	132 [5.21]	150 [5.92]
DLM-12M-100	208.0 [8.189]	133 [5.24]	148.9 [5.864]	218 [8.60]	148.9 [5.864]	149.1 [5.872]		154 [6.07]	172 [6.79]

Dimensions in mm [in]

Loading Information

Forces shown for single bearing units. Values 2X for double bearings -D option.

DLM-12M	Static
Maximum Tensile T	1214 N [273 lbs]
Maximum Compressive C	1214 N [273 lbs]
Maximum Moment M_x	20.6 Nm [182 in-lbs]
Maximum Moment M_y	11.8 Nm [104 in-lbs]
Maximum Payload W	11.8 Nm [104 in-lbs]
Distance to Bearing Centerline	L (see chart above)

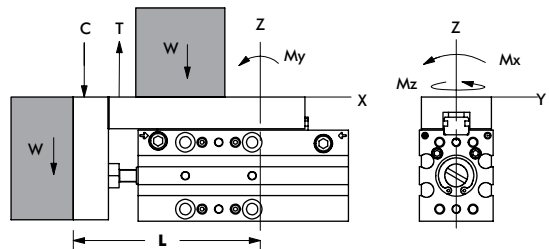

Flow Controls are recommended for all applications

MPS SERIES

Miniature Rail Thruster Slide | Features and Benefits | How To Order

Features:

- Compact high reliability bearing design
- Excellent part position repeatability
- Zero side play with patented preloaded "Dual-V" roller bearings
- Adjustable extend/retract hard stops
- Two Position sensing with hall effect sensors
- Viton® seals for operation in high temperature environments

Applications:

- Precision applications
- Small parts handling
- OEM packaging machines

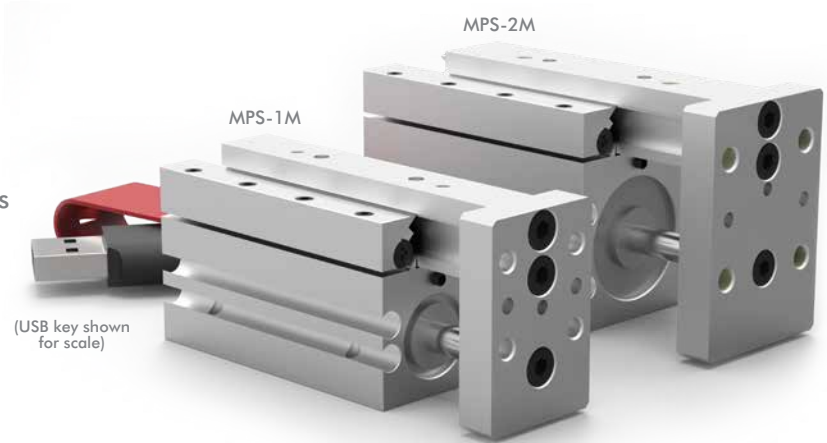

How To Order

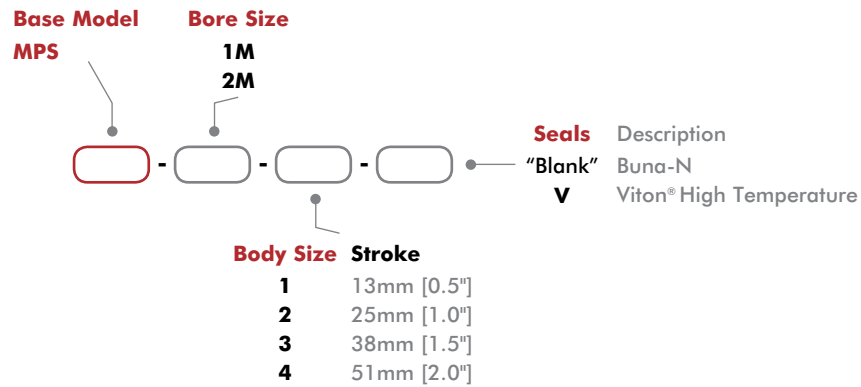

Accessories

Sensor Accessories	Model Numbers	Part Number	Qty/Unit
Magneto Resistive Sensor with Quick. Disconnect*	All Models	OHSN-006	1-2
Magneto Resistive Sensor with Quick. Disconnect*		OHSP-006	
Quick Disconnect 2 Meter Cable Length*		CABL-010	
Quick Disconnect 5 Meter Cable Length*		CABL-013	
Pneumatic Accessories	Model Numbers	Part Number	Qty/Unit
M5 Adjustable Flow Control	All Models	VLVF-008	1-2
M2.5 Barbed Fitting		PLFT-005	2
Seal Kit (Buna-N)	-1M	SLKT-090	1
Seal Kit (Viton®)	-1M	SLKT-090V	
Seal Kit (Buna-N)	-2M	SLKT-091	
Seal Kit (Viton®)	-2M	SLKT-091V	

* Sensor and cable sold separately.

Miniature Rail Thruster Slide | Technical Specifications

Specifications	Units	1M-1	1M-2	1M-3	1M-4
Thrust Force F @ 7 bar [100 psi]	N [lbs]	67 [15]			
Max. Stroke	mm [in]	13 [0.50]	25 [1.00]	38 [1.50]	51 [2.00]
Stroke Adjustability (each end)	mm [in]	3 [0.12]		6 [0.25]	
Weight	kg [lb]	0.08 [0.18]	0.10 [0.22]	0.13 [0.28]	0.14 [0.32]
Max. Payload W	kg [lb]	0.14 [0.30]	0.32 [0.70]	0.45 [1.00]	0.59 [1.30]
Pressure Range	bar [psi]	1.5-7 [20-100]			
Cylinder Bore \varnothing	mm [in]	11.1 [0.438]			
Temperature Range (Buna-N seals)	°C [°F]	-35°~80° [-30°~180°]			
Temperature Range (Viton® seals)	°C [°F]	-30°~120° [-20°~250°]			
Actuation	sec	0.10	0.11	0.13	0.14
Linear Accuracy (per 25mm of travel)	mm [in]	±0.003 [±0.0001]			
Repeatability (-P option)	mm [in]	±0.03 [±0.010]			
Valve to Actuate Double Acting		4-way, 2-position			

Specifications	Units	2M-1	2M-2	2M-3	2M-4
Thrust Force F @ 7 bar [100 psi]	N [lbs]	196 [44]			
Max. Stroke	mm [in]	13 [0.50]	25 [1.00]	38 [1.50]	51 [2.00]
Stroke Adjustability (each end)	mm [in]	3 [0.12]		6 [0.25]	
Weight	kg [lb]	0.12 [0.26]	0.14 [0.32]	0.18 [0.40]	0.21 [0.46]
Max. Payload W	kg [lb]	0.23 [0.50]	0.45 [1.00]	0.91 [2.00]	1.36 [3.00]
Pressure Range	bar [psi]	1.5-7 [20-100]			
Cylinder Bore \varnothing	mm [in]	19.1 [0.750]			
Temperature Range (Buna-N seals)	°C [°F]	-35°~80° [-30°~180°]			
Temperature Range (Viton® seals)	°C [°F]	-30°~120° [-20°~250°]			
Actuation	sec	0.12	0.16	0.19	0.24
Linear Accuracy (per 25mm of travel)	mm [in]	±0.003 [±0.0001]			
Repeatability (-P option)	mm [in]	±0.03 [±0.010]			
Valve to Actuate Double Acting		4-way, 2-position			

MPS-1M

Miniature Rail Thruster Slide | Dimensions and Technical Specifications

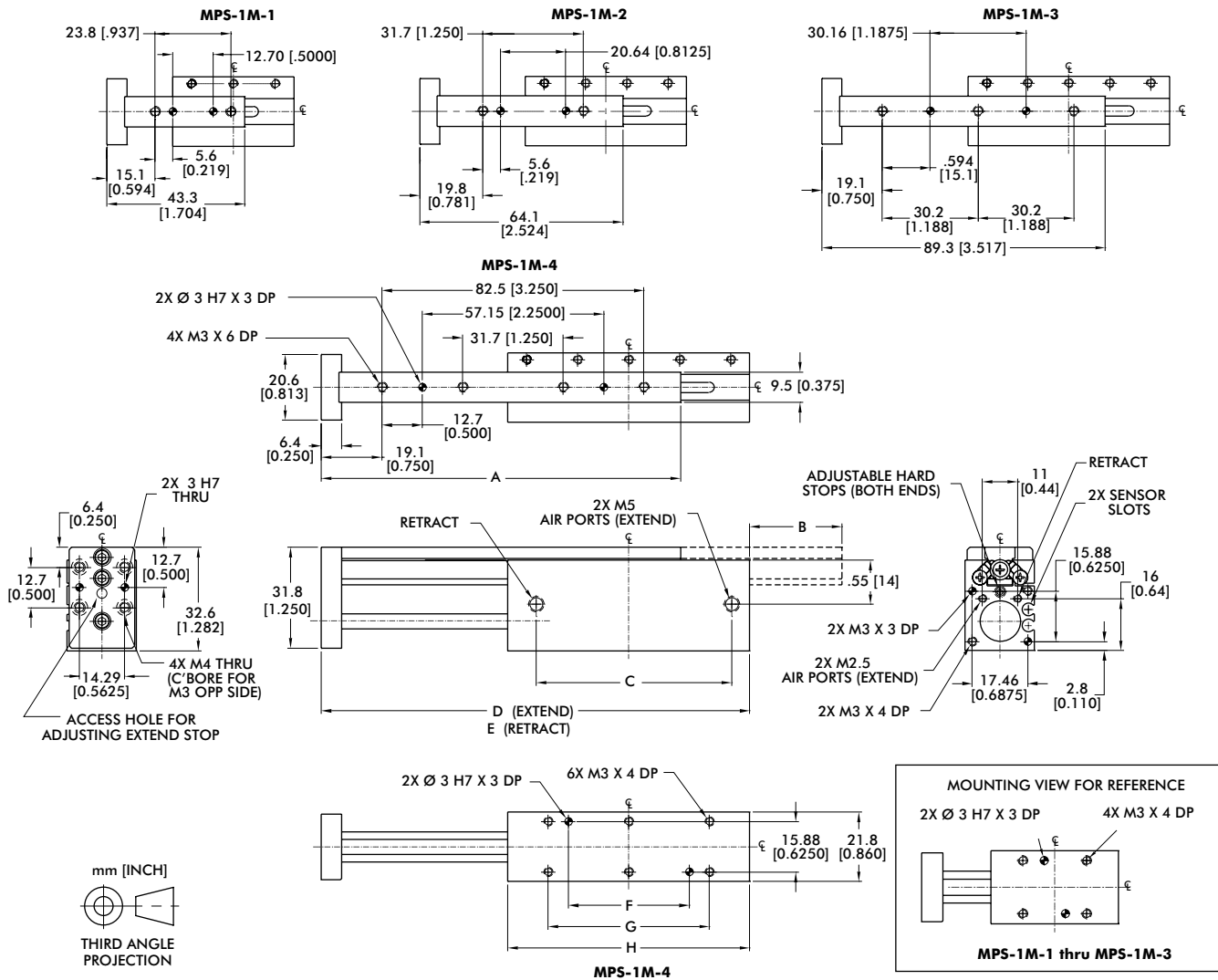

Model	A	B	C	D	E	F	G	H
MPS-1M-1	43.3 [1.704]	--	23 [0.92]	59 [2.31]	46 [1.81]	6.35 [0.2500]	19.1 [0.750]	38.1 [1.500]
MPS-1M-2	64.1 [2.524]	5.4 [0.211]	36 [1.43]	84 [3.31]	58 [2.31]	19.05 [0.7500]	31.8 [1.250]	50.8 [2.000]
MPS-1M-3	89.3 [3.517]	17.9 [0.704]	49 [1.93]	110 [4.31]	71 [2.81]	25.40 [1.0000]	38.1 [1.500]	63.5 [2.500]
MPS-1M-4	113.1 [4.454]	29.0 [1.141]	62 [2.43]	135 [5.31]	84 [3.31]	38.10 [1.5000]	50.8 [2.000]	76.2 [3.000]

Dimensions in mm [in]

Loading Information

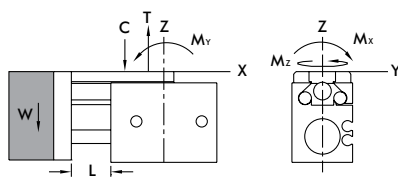

MPS-1M-1	Static
Maximum Tensile T	111 N [25 lbs]
Maximum Compressive C	111 N [25 lbs]
Maximum Moment M_x	3.4 Nm [30 in-lbs]
Maximum Moment M_y	2.3 Nm [20 in-lbs]
Maximum Moment M_z	2.3 Nm [20 in-lbs]

MPS-1M-3	Static
Maximum Tensile T	222 N [50 lbs]
Maximum Compressive C	222 N [50 lbs]
Maximum Moment M_x	6.8 Nm [60 in-lbs]
Maximum Moment M_y	4.5 Nm [40 in-lbs]
Maximum Moment M_z	4.5 Nm [40 in-lbs]

MPS-1M-2	Static
Maximum Tensile T	156 N [35 lbs]
Maximum Compressive C	156 N [35 lbs]
Maximum Moment M_x	4.5 Nm [40 in-lbs]
Maximum Moment M_y	3.4 Nm [30 in-lbs]
Maximum Moment M_z	3.4 Nm [30 in-lbs]

MPS-1M-4	Static
Maximum Tensile T	311 N [70 lbs]
Maximum Compressive C	311 N [70 lbs]
Maximum Moment M_x	9.0 Nm [80 in-lbs]
Maximum Moment M_y	5.7 Nm [50 in-lbs]
Maximum Moment M_z	5.7 Nm [50 in-lbs]

Miniature Rail Thruster Slide | Dimensions and Technical Specifications

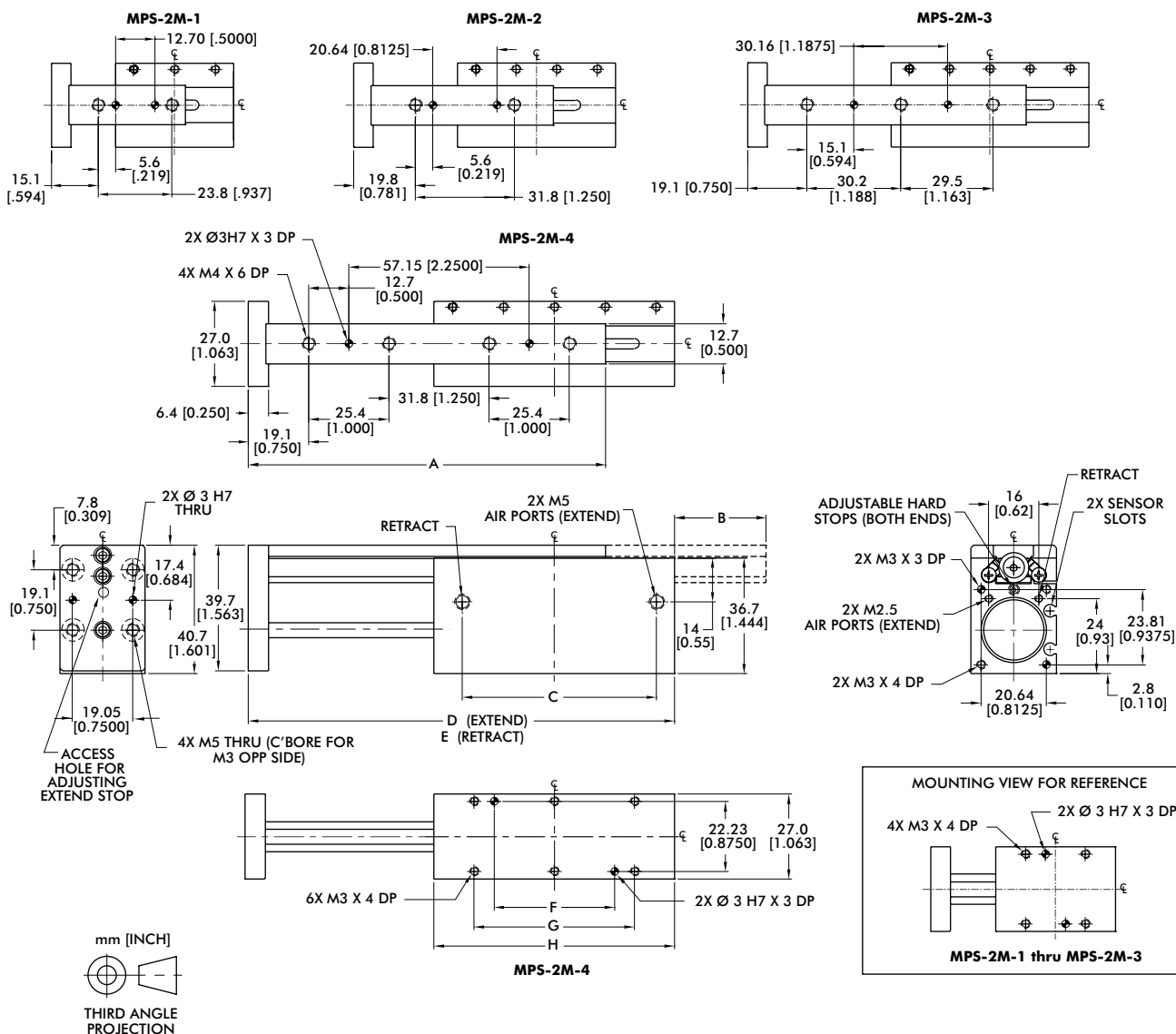

Model	A	B	C	D	E	F	G	H
MPS-2M-1	43.3 [1.704]	--	23 [0.92]	59 [2.31]	46 [1.81]	6.35 [0.2500]	19.1 [0.750]	38.1 [1.500]
MPS-2M-2	64.1 [2.524]	5.4 [0.211]	36 [1.43]	84 [3.31]	59 [2.31]	19.05 [0.7500]	31.7 [1.250]	50.8 [2.000]
MPS-2M-3	89.5 [3.524]	17.9 [0.704]	49 [1.92]	110 [4.31]	71 [2.81]	25.40 [1.0000]	38.1 [1.500]	63.5 [2.500]
MPS-2M-4	113.1 [4.454]	29.0 [1.141]	62 [2.42]	135 [5.31]	84 [3.31]	38.10 [1.5000]	50.8 [2.000]	76.2 [3.000]

Dimensions in mm [in]

Loading Information

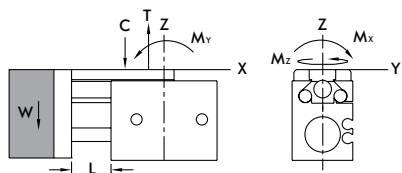

MPS-2M-1	Static	MPS-2M-3	Static
Maximum Tensile T	111 N [25 lbs]	Maximum Tensile T	222 N [50 lbs]
Maximum Compressive C	111 N [25 lbs]	Maximum Compressive C	222 N [50 lbs]
Maximum Moment M_x	3.4 Nm [30 in-lbs]	Maximum Moment M_x	6.8 Nm [60 in-lbs]
Maximum Moment M_y	2.3 Nm [20 in-lbs]	Maximum Moment M_y	4.5 Nm [40 in-lbs]
Maximum Moment M_z	2.3 Nm [20 in-lbs]	Maximum Moment M_z	4.5 Nm [40 in-lbs]

MPS-2M-2	Static	MPS-2M-4	Static
Maximum Tensile T	156 N [35 lbs]	Maximum Tensile T	311 N [70 lbs]
Maximum Compressive C	156 N [35 lbs]	Maximum Compressive C	311 N [70 lbs]
Maximum Moment M_x	4.5 Nm [40 in-lbs]	Maximum Moment M_x	9.0 Nm [80 in-lbs]
Maximum Moment M_y	3.4 Nm [30 in-lbs]	Maximum Moment M_y	5.7 Nm [50 in-lbs]
Maximum Moment M_z	3.4 Nm [30 in-lbs]	Maximum Moment M_z	5.7 Nm [50 in-lbs]